



Coimisiún na Scrúduithe Stáit
State Examinations Commission

LEAVING CERTIFICATE EXAMINATION, 2003

PHYSICS – ORDINARY LEVEL

MONDAY, 16 JUNE – MORNING 9.30 TO 12.30

Answer **three** questions from **section A** and **five** questions from **section B**.

SECTION A (120 marks)

Answer **three** questions from this section.
Each question carries 40 marks.

1. A student carried out an experiment to investigate the relationship between the force applied to a body and the acceleration of the body. The table shows the measurements recorded by the student.

Force/N	0.1	0.2	0.3	0.4	0.5	0.6	0.7	0.8
Acceleration/cm s ⁻²	8.4	17.6	25.4	35.0	43.9	51.5	60.4	70.0

- Draw a labelled diagram of the apparatus used in the experiment. (9)
- How was the effect of friction reduced in the experiment? (6)
- Describe how the student measured the applied force. (9)
- Plot a graph, on graph paper, of the acceleration against the applied force. (12)
- What does your graph tell you about the relationship between the acceleration of the body and the force applied to it? (4)
2. In a report of an experiment to measure the specific latent heat of fusion of ice, a student wrote the following.
- “Ice at 0 °C was added to water in a calorimeter.
When the ice had melted measurements were taken.
The specific latent heat of fusion of ice was then calculated.”
- Draw a labelled diagram of the apparatus used. (12)
- What measurements did the student take before adding the ice to the water? (9)
- What did the student do with the ice before adding it to the water? (6)
- How did the student find the mass of the ice? (9)
- Give one precaution that the student took to get an accurate result. (4)

3. In an experiment to measure the speed of sound in air, a student found the frequency and the wavelength of a sound wave.

Draw a labelled diagram of the apparatus used in the experiment. (12)

Describe how the student found the wavelength of the sound wave. (9)

How did the student find the frequency of the sound wave? (6)

How did the student calculate the speed of sound in air? (9)

Give one precaution that the student took to get an accurate result. (4)

4. The diagram shows the circuit used by a student to investigate the variation of current with potential difference for a filament bulb.

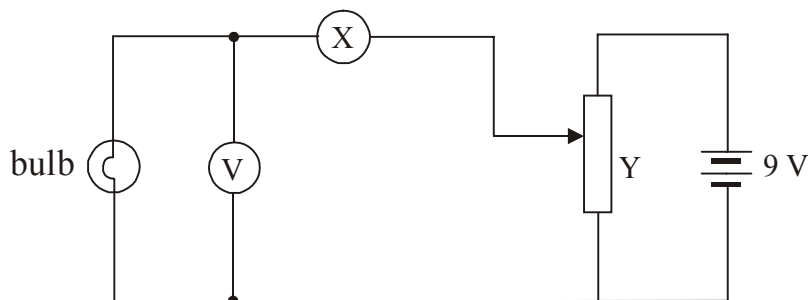

Name the apparatus X. What does it measure? (6)

Name the apparatus Y. What does it do? (6)

The table shows the values obtained for the current and the potential difference during the experiment.

Potential difference/V	2.0	3.0	4.0	5.0	6.0	7.0	8.0	9.0
Current/A	1.0	1.5	1.9	2.3	2.6	2.9	3.2	3.5

Draw a graph, on graph paper, of the current against the potential difference. (12)

The resistance of the bulb is 2.0Ω when the current is 1.5 A.

Use your graph to find the resistance of the bulb when the current is 3 A. (10)

Explain why the resistance of the bulb when the current is 1.5 A is different from its resistance when the current is 3 A. (6)

SECTION B (280 marks)

Answer **five** questions from this section.

Each question carries 56 marks.

5. Answer any **eight** of the following parts (a), (b), (c), etc.

- (a) What is the momentum of an object with a mass of 5 kg travelling at 10 m s^{-1} ? (7)
- (b) State Boyle's law. (7)
- (c) Name a renewable source of energy. (7)
- (d) The temperature of a body is 300 K. What is its temperature in degrees Celsius? (7)
- (e) Name two methods by which heat can be transferred. (7)
- (f) Give one difference between light waves and sound waves. (7)
- (g) Describe the image that is formed in a concave mirror when an object is placed inside the focus, as shown in the diagram. (7)

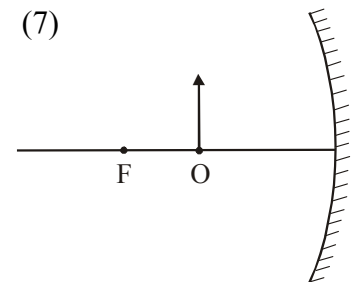

- (h) State one energy conversion that takes place in an electrical generator. (7)
- (i) What is a transformer used for? (7)
- (j) Give two properties of the electron. (7)

$$(p = mv)$$

6. Copy and complete the following statement of Newton's law of universal gravitation.

"Any two point masses attract each other with a which is proportional to the product of their and inversely proportional to the between them." (12)

What is meant by the term acceleration due to gravity? (6)

An astronaut of mass 120 kg is on the surface of the moon, where the acceleration due to gravity is 1.6 m s^{-2} . What is the weight of the astronaut on the surface of the moon? (6)

The astronaut throws a stone straight up from the surface of the moon with an initial speed of 25 m s^{-1} . Describe how the speed of the stone changes as it reaches its highest point. Calculate the highest point reached by the stone. (18)

Calculate how high the astronaut can throw the same stone with the same initial speed of 25 m s^{-1} when on the surface of the earth, where the acceleration due to gravity is 9.8 m s^{-2} . (9)

Why is the acceleration due to gravity on the moon less than the acceleration due to gravity on the earth? (5)

$(W = mg; v^2 = u^2 + 2as)$

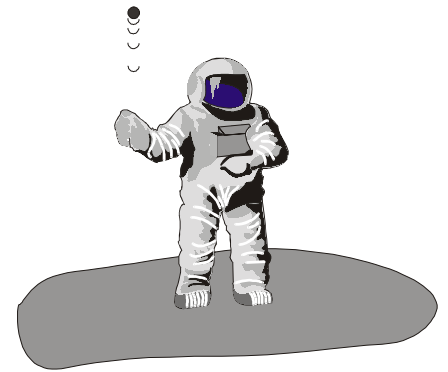

7. State the laws of refraction of light. (12)

Explain, with the aid of a labelled diagram, (i) total internal reflection, (ii) critical angle. (12)

The diagram shows a 45° prism made of glass. The critical angle for the glass is 42° . Calculate the refractive index of the glass. (9)

The diagram shows a ray of light entering the prism from air. Copy the diagram and show the path of the ray through the prism and back into the air. Explain why the ray follows the path that you have shown. (15)

Give two uses of total internal reflection. (8)

$(n = \frac{1}{\sin C})$

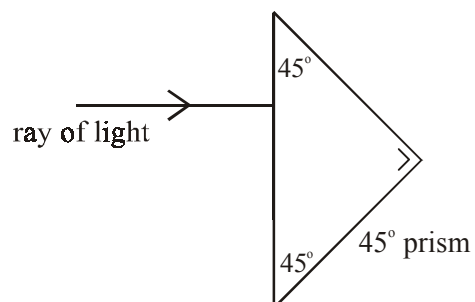

8. What is an electric current? (6)

Give the standard colour of the insulation on the wires connected to each of the terminals L, N and E on the plug in the diagram. What is the purpose of the wire connected to the terminal E on the plug? (15)

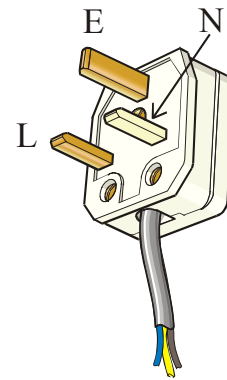

Explain why a fuse is used in a plug. (6)

The fuse in the plug of an electric kettle was replaced with a 5 A fuse. The kettle has a power rating of 2 kW when connected to the ESB mains voltage of 230 V.

Calculate the current that flows when the kettle is first plugged in.

This current will only flow for a very short time. Explain why. (15)

Bonding is a safety precaution used in domestic electric circuits. How does bonding improve safety in the home? (9)

Name a device that is often used nowadays in domestic electric circuits instead of fuses. (5)

$$(P = VI)$$

9. What is a magnetic field? (6)

The earth has a magnetic field. Give one use of the earth's magnetic field. (5)

Hans Oersted discovered the magnetic effect of an electric current in 1820 while demonstrating electricity to his students. Describe how you would demonstrate the magnetic effect of an electric current. (18)

Draw a sketch of the magnetic field around a straight wire carrying a current. Your diagram should show the direction of the current and the direction of the magnetic field. (9)

In an experiment, a thin light conductor is placed between the poles of a U-shaped magnet as shown in the diagram. Describe what happens when a current flows through the conductor.

Name two devices that are based on the effect demonstrated in this experiment. (12)

What would happen if (i) a larger current flowed in the conductor, (ii) the current flowed in the opposite direction through the conductor? (6)

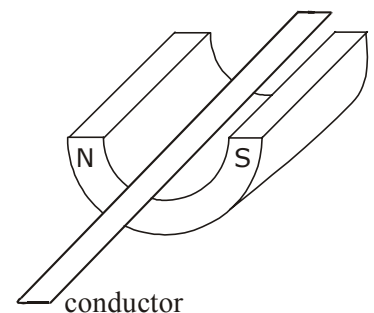

10. What is radioactivity? (6)

The diagram shows the basic structure of a nuclear reactor.

A nuclear reactor contains (i) fuel rods, (ii) control rods, (iii) moderator, (iv) heat exchanger.

Give the function of any two of these. (12)

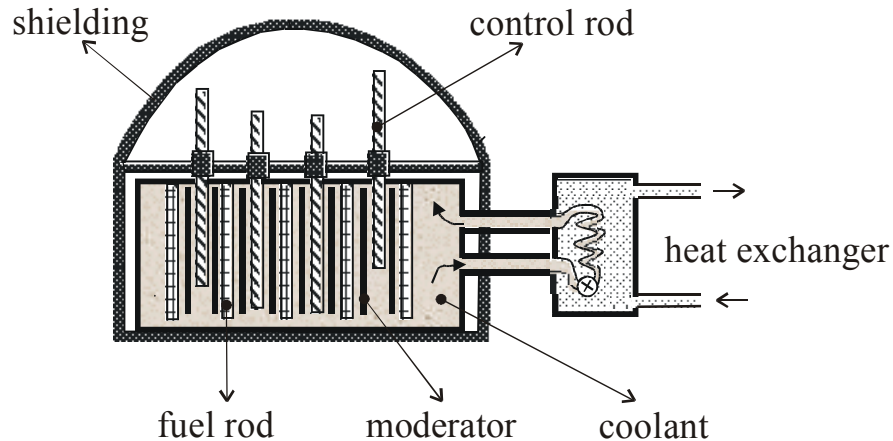

In a nuclear reactor, energy is released by nuclear fission when a chain reaction occurs.

What is nuclear fission?

What is a chain reaction? (18)

Thick shielding is placed around a nuclear reactor because of the penetrating power of the radiation emitted. Name three types of radiation that are present in a nuclear reactor.

Name an instrument used to detect radiation. (14)

Plutonium is produced in a nuclear reactor. It is a highly radioactive substance with a very long half-life. When the fuel in a nuclear reactor is used up, the fuel rods are reprocessed to remove the plutonium.

Give two precautions that are taken when storing the plutonium. (6)

11. Read the following passage and answer the accompanying questions.

The operation of semiconductor devices depends on the effects that occur when p-type and n-type semiconductor material are in close contact. This is achieved by taking a single crystal of silicon and doping separate but adjacent layers of it with suitable impurities. The junction between the p-type and the n-type layers is referred to as the *p-n junction* and this is the key to some very important aspects of semiconductor theory. Devices such as diodes, transistors, silicon-controlled rectifiers, etc., all contain one or more p-n junctions.

(“Physics – a teacher’s handbook”, Dept. of Education and Science.)

- (a) What is a semiconductor? (7)
- (b) Name a material used in the manufacture of semiconductors. (7)
- (c) Name the two types of charge carriers in semiconductors. (7)
- (d) What is meant by doping? (7)
- (e) Give one difference between a p-type semiconductor and an n-type semiconductor. (7)
- (f) What is a p-n junction? (7)
- (g) What is a diode? (7)
- (h) Give an example of a device that contains a rectifier. (7)

12. Answer any **two** of the following parts (a), (b), (c), (d).

(a) Define the moment of a force. (6)

Explain why the handle on a door is on the opposite side to the hinges of the door. (7)

A metre stick is suspended by a thread at the 20 cm mark as shown in the diagram. The weight W of the metre stick acts through the 50 cm mark. A weight of 2 N is placed at the 15 cm mark.

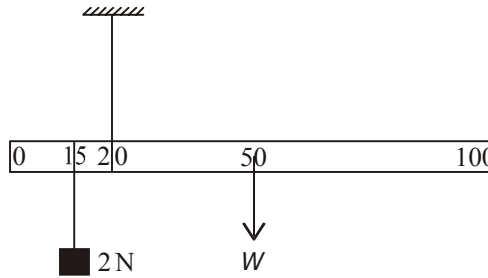

Calculate the moment of the 2 N weight about the 20 cm mark. (5)

What is the moment of W about the 20 cm mark? (5)

If the metre stick is in equilibrium, find the value of W . (5)

$(M = Fd)$

(b) Name two primary colours. (6)

What are complementary colours? (6)

White light is made up of light of different colours. Describe an experiment to demonstrate this. (9)

The diagram shows a simple form of the electromagnetic spectrum, with wavelength increasing from left to right.

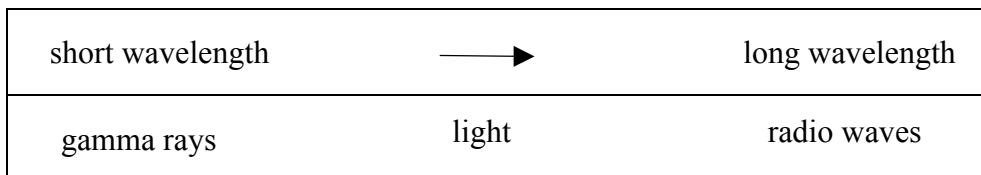

Copy this diagram and indicate on it the positions of the following:
microwaves; infrared; ultraviolet; X-rays. (7)

(c) What is the unit of electric charge? (6)

Describe, with the aid of a labelled diagram, how you would charge a conductor by induction. (12)

The build-up of electric charge can lead to explosions. Give two examples where this could happen. (6)

How can the build-up of electric charge on an object be reduced? (4)

(d) What is a photon? (6)

The diagram shows a photocell connected in series with a sensitive galvanometer and a battery. Name the parts labelled A and B. (6)

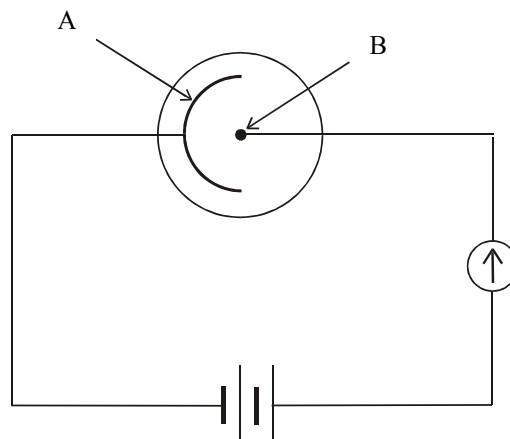

What happens at A when light falls on it? (6)

What happens in the circuit when the light falling on A gets brighter? (6)

Give an application of a photocell. (4)

Blank Page

Blank Page