

# JUNIOR CERTIFICATE 2001 MATERIALS TECHNOLOGY (WOOD)

## MARKING SCHEME - ORDINARY LEVEL

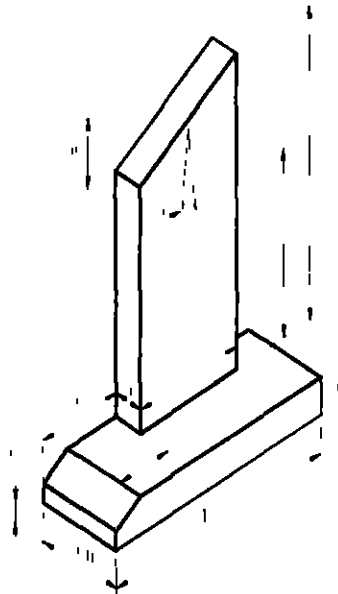

### SECTION A







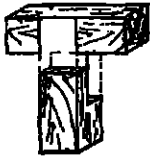

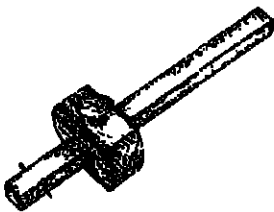
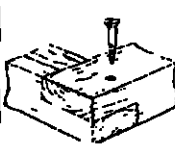
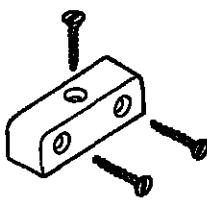
#### **NOTE**

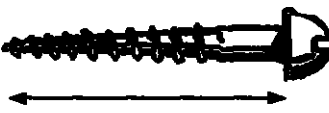
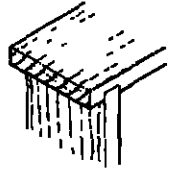
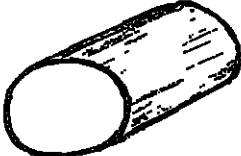
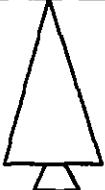

**Please ensure that totals for each question are divided by TWO  
before entering marks on marking sheets**

**SECTION A – Short Answers**  
**Mark all questions, select the best 16 questions**  
**This section is marked out of 80 marks**  
**Divide the final mark by 2 on completion of marking**

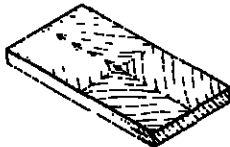
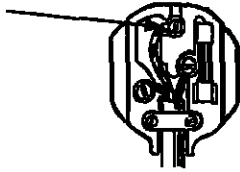
Q	SOLUTION	MARKS	DIAGRAM (IF ANY)
1	Complete Sketch	5 marks	
2a	<i>Name:</i> Chisel / Firmer Chisel  <i>Use:</i> Cutting / Paring / Chopping.	Either. 3 marks  Both 5 marks	
OR		OR	
2b	<i>Name:</i> Marking Gauge/ Gauge  <i>Use:</i> Marking to width / thickness Marking lines	Either: 3 marks  Both 5 marks	
3	To prevent the wood from splitting/ Easier to insert screw	5 marks	
4	<i>Name:</i> Block Joint/ Knockdown Fitting(KD) Modesty Block <i>Use:</i> Join panels at right Angles	Either 3 marks  Both. 5 marks	

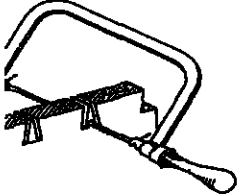
Q	SOLUTION	MARKS	DIAGRAM (IF ANY)
5	<b>Name:</b> <b>A: Oak</b> <b>B: Holly</b>	Either <b>3 marks</b> Both <b>5 marks</b>	
6	Arrows for length	<b>5 marks</b>	
7	<b>Electric Sander:</b> <b>Two safety rules:</b> Wear: Goggles Ear Muffs Mask Proper Clothing Sound. Plug Cables Safe work practices etc.	Any One <b>3 marks</b> TWO <b>5 marks</b>	
8	<b>Name Joint:</b> Housing/Housed	<b>5 marks</b>	
9	Show Annual Rings	<b>5 marks</b>	
10	Outline of Coniferous Tree	<b>5 marks</b>	
11	<b>Advantages of Plywood :</b> Large Sheets / Stable Strength / No splitting near edges / Economical of expensive woods Expensive facing veneers etc	Any One <b>3 marks</b> TWO <b>5 marks</b>	

Q	SOLUTION	MARKS	DIAGRAM (IF ANY)
12	Complete sketch to show Shaving	5 marks	
13	<p><b>Function of A and B</b></p> <p><b>A:</b> Hold piece at head - stock, Enable piece to rotate Centre wood on lathe</p> <p><b>B</b> Enable piece to rotate at Tailstock Centre wood on lathe etc</p>	<p>Function of A or B 3 marks</p> <p>Function of A and B 5 marks</p>	<p>A</p>  <p>B</p> 
14	<p><b>Name:</b> Veneers</p>	5 marks	
15	Arrow to show Earth Terminal	5 marks	
16	Arrows to show directions of spoke - shaving	<p>One arrow 3 marks Both 5 marks</p>	
17	Coping Saw	5 marks	

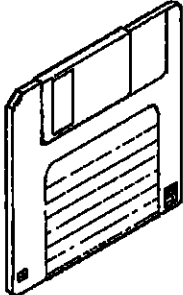
Q	SOLUTION	MARKS	DIAGRAM (IF ANY)
18	Complete sketch to show tang	5 marks	
19	<p><i>Protective eye-wear</i></p> <p><i>Two activities:</i></p> <p>Wood turning, Cutting on bandsaw Drilling with drillstand Sanding with sander Spray Painting Welding etc</p>	<p>Any one: 3 marks</p> <p>TWO. 5 marks</p>	
20	<p><i>Two storage precautions:</i></p> <p>Dry Away from direct heat Away from dust Away from magnets Away from speakers In container etc.</p>	<p>Any one 3 marks</p> <p>TWO 5 marks</p>	

**SECTION A**

***NOTE:***

***Divide final mark by 2 on completion of marking of this section***

**JUNIOR CERTIFICATE 2001**  
**MATERIALS TECHNOLOGY**  
**(WOOD)**

**MARKING SCHEME**

**ORDINARY LEVEL**

**SECTION B**

**NOTE**

**Please ensure that totals for each question are divided by TWO  
before entering marks on marking sheets**

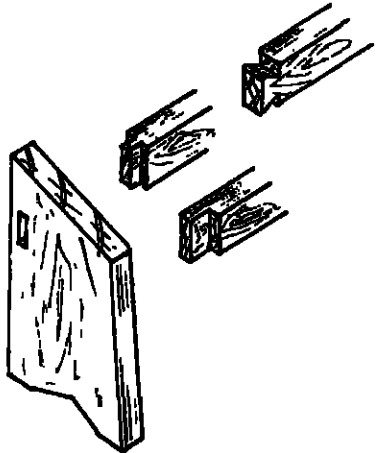
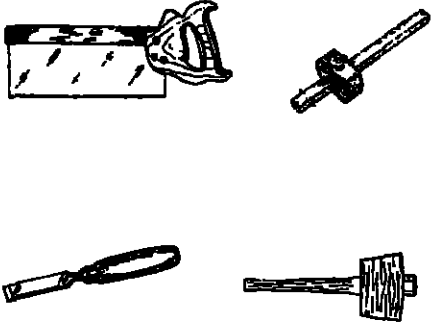
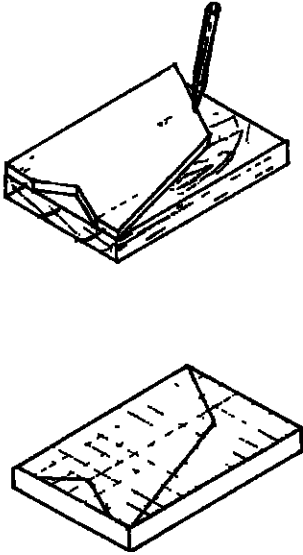

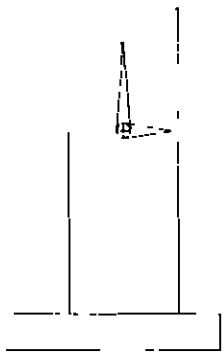
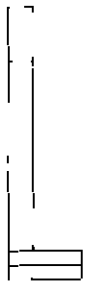
Q	Sketches	Notes	Marks
Q1(i)		<p>Any joint suitable for jointing back to rail</p> <p><b>Sketches</b></p>	20
Q1(ii)		<p>Any tool used in making joint</p> <p><b>Sketch</b></p> <p><b>Name tool and list parts</b></p>	10 5
Q1(iii)		<p>Use of template or grid to transfer shape to rectangular board</p> <p><b>Notes and sketches on how to use template</b></p>	5

Q	Sketches	Notes	Marks
Q2(i)	 <p style="text-align: center;"><b>Elevation</b></p>	<ol style="list-style-type: none"> <li>1. Overall height</li> <li>2. Overall width of base</li> <li>3. Overall width of back</li> <li>4. Slope at top</li> <li>5. Chamfer at base</li> </ol>	<p style="text-align: center;">4</p> <p style="text-align: center;">4</p> <p style="text-align: center;">4</p> <p style="text-align: center;">4</p> <p style="text-align: center;">4</p>
Q2 (ii)	 <p style="text-align: center;"><b>End Elevation</b></p>	<ol style="list-style-type: none"> <li>1 Overall heights</li> <li>2. Width of base</li> <li>3. Sloping lines (2 x 2 Marks)</li> </ol>	<p style="text-align: center;">4</p> <p style="text-align: center;">4</p> <p style="text-align: center;">4</p>
Q2 (iii)	<p style="text-align: center;"><b>DIMENSIONS</b></p> <p style="text-align: center;"><b>ARROWHEADS</b></p>	<p><b>ONE</b> mark for each correct dimension (4x 1 mark)</p> <p><b>One</b> marks for each correct arrowhead (4x 1 mark)</p>	<p style="text-align: center;">4</p> <p style="text-align: center;">4</p>

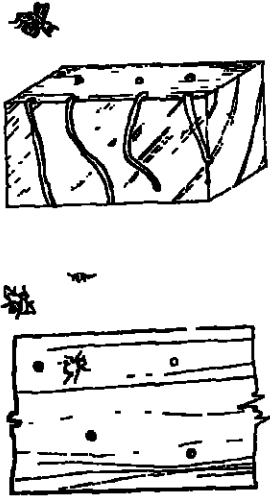

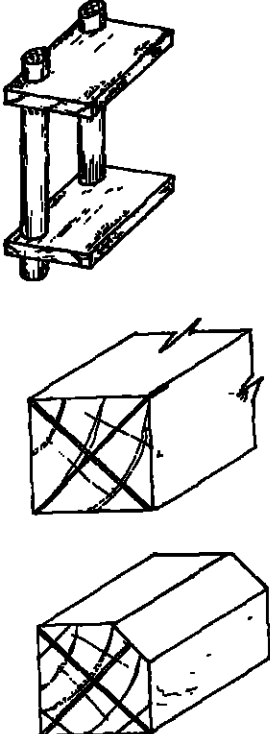
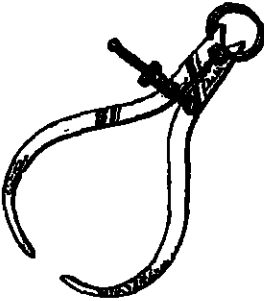
Q	Sketches	Notes	Marks
Q3 (i)	 <p style="text-align: center;"><i>Sketch</i></p>	<ol style="list-style-type: none"> <li>1. Adult beetle lays eggs</li> <li>2. Eggs hatch into grubs/worms</li> <li>3. The grub eats its way into the wood causing great damage to the wood</li> </ol> <p style="text-align: center;"><i>Notes and Sketches</i></p> <p style="text-align: center;"><i>Either notes or sketches</i></p>	<p style="text-align: center;">20</p> <p style="text-align: center;">15</p>
Q3 (ii)		<p style="text-align: center;"><b>To prevent attack</b>            Treat the wood with a preservative containing an Insecticide            Or            Use a gloss varnish on the new wood to help prevent attack</p>	<p style="text-align: center;">12</p> <p style="text-align: center;"><b>OR</b></p> <p style="text-align: center;">12</p>
Q3 (iii)		<p style="text-align: center;"><b>To prevent Re-infestation</b>            Examine extent of attack and replace infected woods or plywood if necessary            Treat all infected areas and surrounding wood liberally with insecticide            Monitor for further infestation and retreat</p>	<p style="text-align: center;">8</p>

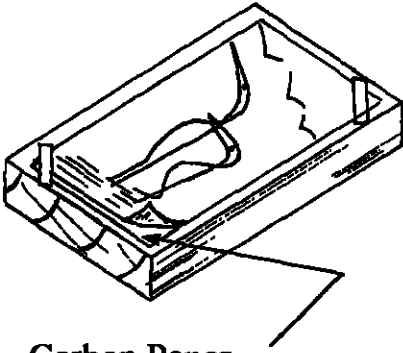
Q	Sketches	Notes	Marks
Q4 (i)		<ol style="list-style-type: none"> <li>1. Join the diagonals to determine centre of piece.</li> <li>2. Remove corners to allow for safe turning.</li> </ol> <p style="text-align: center;"><i>Sketches</i> (2 x 6 marks)</p>	<p style="text-align: center;">4</p> <p style="text-align: center;">4</p> <p style="text-align: center;">12</p>
Q4 (ii)		<p style="text-align: center;"><b>To determine same diameter</b></p> <p>Measure diameter with calipers</p> <p style="text-align: center;">Sketch</p>	<p style="text-align: center;">4</p> <p style="text-align: center;">4</p>
Q4 (iii)		<p><b>THREE safety Precautions:</b></p> <ol style="list-style-type: none"> <li>1. No loose clothing</li> <li>2. Wear eye protection</li> <li>3. One person at the lathe</li> <li>4. Long hair tied back</li> <li>5. Wear dust mask etc</li> </ol>	<p style="text-align: center;"><i>Any three</i></p> <p style="text-align: center;">4</p> <p style="text-align: center;">4</p> <p style="text-align: center;">4</p>

Q	Sketches	Notes	Marks
Q4 B			
Q4 (i)		Name of Carving. <i>Incised Carving</i>	4
Q4 (ii)	 <p>Carbon Paper</p>	Transferring Shape: <i>Sketch</i>  <i>Notes</i> Carbon paper to transfer design on to wood. Use of grid paper	12  8
Q4 (iii)	 <p>OR</p> 	Vee-Tool OR Vener  <i>Sketch</i>  <i>Name Parts</i>	  12  4

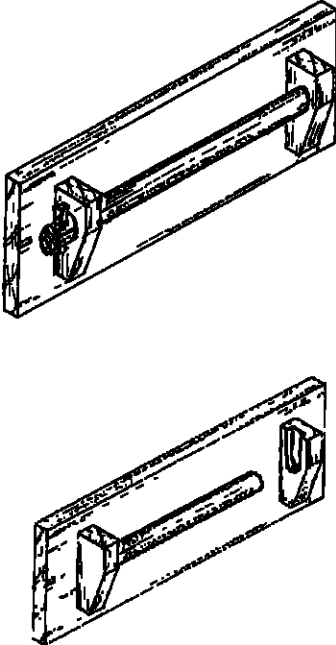
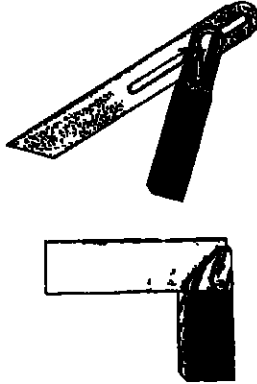
Q	Sketches	Notes	Marks
Q5(i)		<p>To remove rail</p> <p><i>Sketch</i></p> <p><i>Notes</i></p>	<p>8</p> <p>8</p>
Q5 (ii)		<p>Marking - out tool</p> <p><i>Sketch</i></p>	<p>12</p>
Q5 (iii)		<p>Alternative design for back</p> <p><i>Sketch</i></p>	<p>12</p>

Please ensure that totals are divided by **TWO** before entering marks on marking sheets