



# Coimisiún na Scrúduithe Stáit State Examinations Commission

**Higher Level Marking Scheme**

**Higher Level Solutions**

**Practical Test**

**Practical Coursework English Version and Irish Version**

*Scéimeanna Marcála*

*Scrúduithe Ardteistiméireachta, 2005*

*Staidéar Foirgníochta*

*Ardleibheal*

*Marking Scheme*

*Leaving Certificate Examination, 2005*

*Construction Studies*

*Higher Level*



Coimisiún na Scrúduithe Stáit  
*State Examinations Commission*

*Scrúdú Ardteistiméireachta 2005*

*Staidéar Foirgníochta*  
*Teoiric – Ardleibhéal*

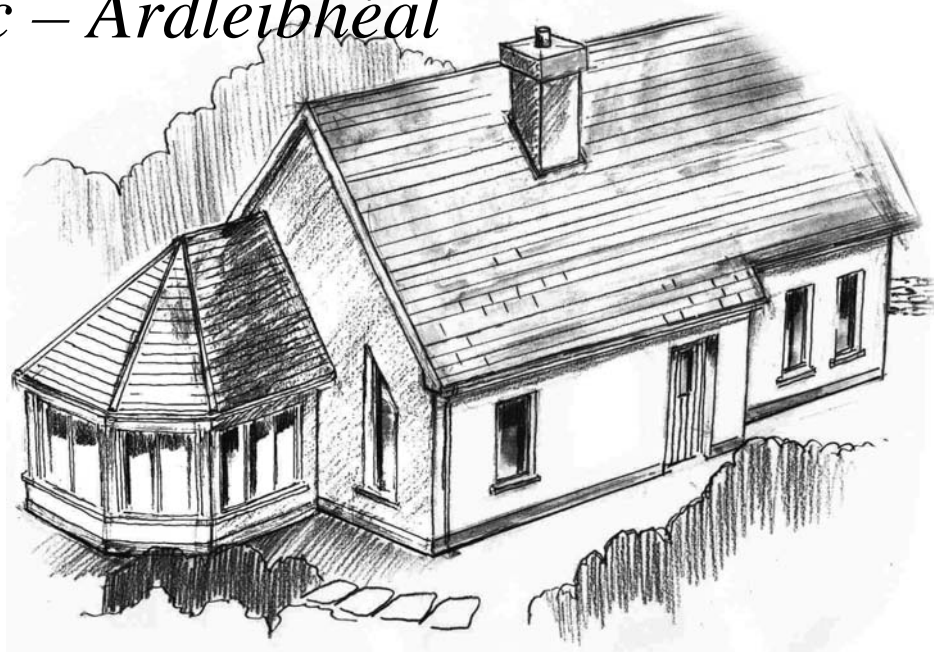

*Construction Studies*  
*Theory – Higher Level*

FREAGRAÍ  
*SOLUTIONS*

**CEIST 1**

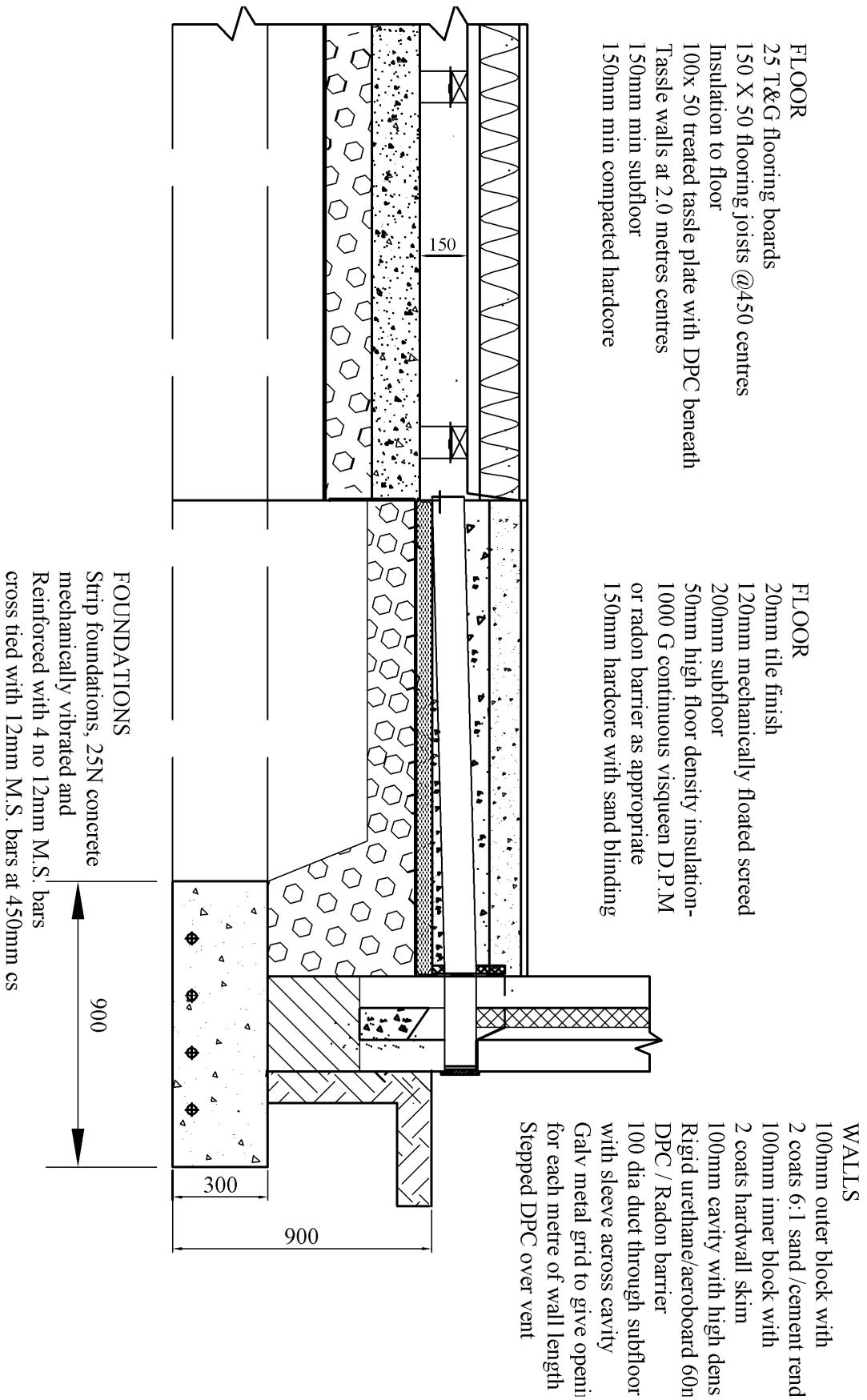

**Section A-A**

## Ceist 2a

Areas that require specific consideration

- 1 Entrance/Hallway
- 2 Kitchen
- 3 Bathroom

Any other relevant areas

### 1 Entrance/Hallway

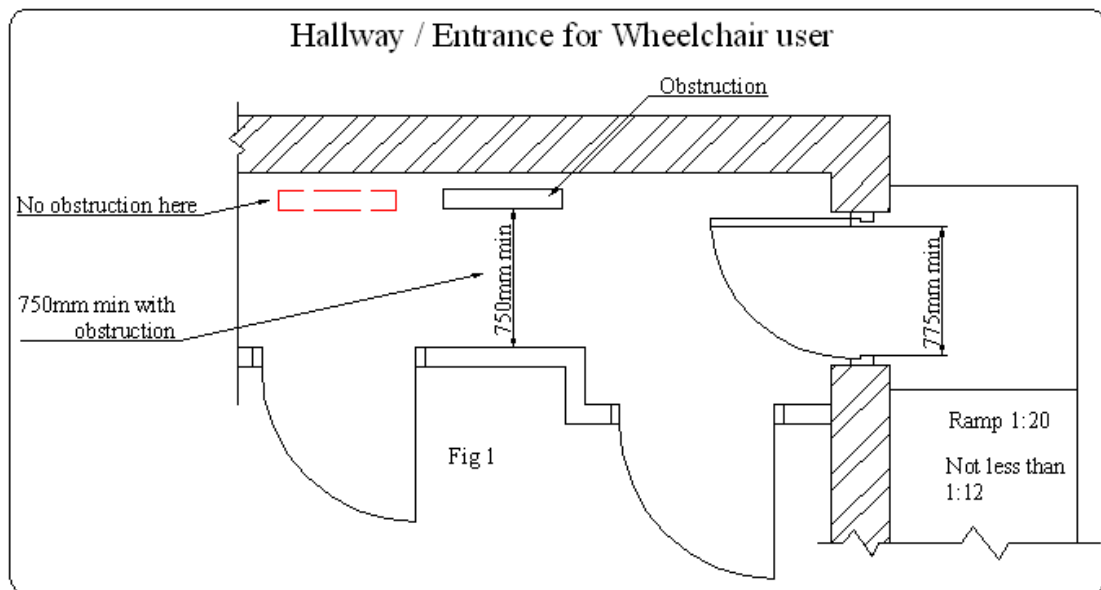

### Kitchen for wheelchair user

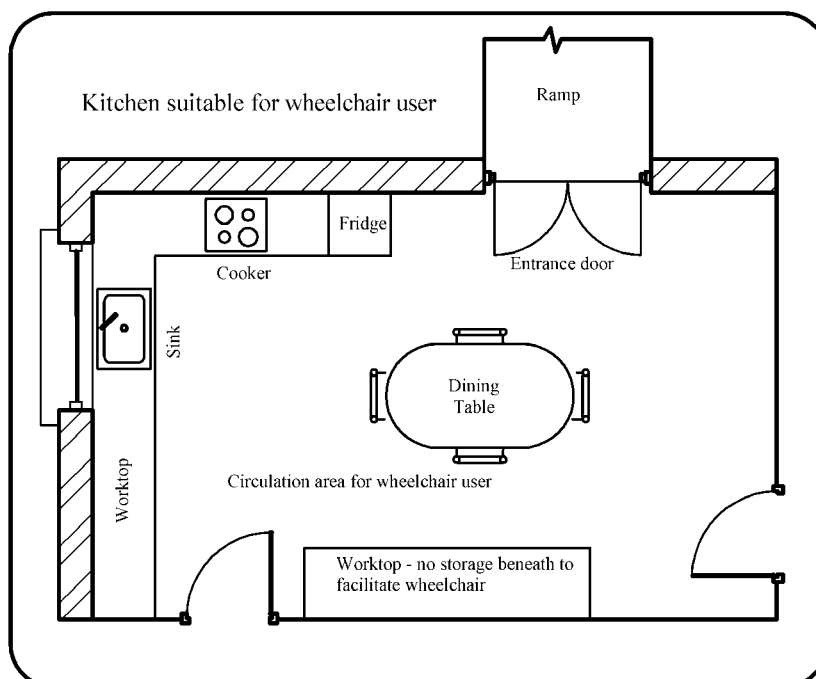

## **Ceist 2b**

*Sketches and all other relevant information on the following:*

### **Entrance/Hallways**

- The approach to each dwelling should have at least one entrance (preferably the main entrance) which is accessible by wheelchair users.
- Doors must have a minimum clear opening for wheelchair accessibility of between 750mm and 800mm.
- Threshold height max 15mm.
- No door saddles preferable. Saddles if used should be bevelled and have a max thickness of 10mm.
- Door handles, light switches, doorbells should be located at a height of between 900mm and 1200mm .
- No obstructions such as radiators or furniture near door openings.
- Provision of ramped access where possible. Level landings must be provided at regular intervals -interval depends on slope- and level in front of main door.
- Corridors should have a minimum unobstructed width of 900mm.
- There should be access to a WC from the accessible wheelchair entrance without the need to negotiate steps.

*Any other relevant information.*

### **Kitchen**

- Adequate unobstructed space to turn the wheelchair 1500mm dia turning circle
- Unobstructed spaces at doorways to allow ease of entry/exit
- All frequently used appliances such as toaster, microwave to be accessible.
- Dishwasher, washing machine to be built under work surfaces.
- Power points at heights to allow use from wheelchair.
- Varying heights for work surfaces. Worktop and sink at reduced height (800mm)
- Lowered light switches (between 900&1200mm)
- Circular/elliptical table for ease of circulation
- Open space underneath worktops and sinks to allow knee space
- Reduced cill height to allow view from the chair and access to open/close window
- Non slip floor surfaces
- No changes of level or steps
- Open shelving for ease of storage
- Different height shelving to facilitate ease of access to stored items.

*Any other relevant information.*

## **Bathroom**

- Wall mounted sink. No pedestal beneath to allow easy wheelchair access.
- Special tap fittings, Lever arm controls for ease of use
- 1500mm turning circle to allow easy access to all appliances
- Wheelchair access to the window
- Vertical and horizontal grab rails. To be positioned 700mm above floor level, 600mm long and of 35mm diameter
- Fold up grab rail 400mm from WC centreline in conjunction with horizontal grab rail to allow a firm grip
- Flush finish shower tray for ease of entry
- Fabric shower curtain for ease of opening
- Flip-up shower seat
- Non-slip floor surfaces

Any other relevant information

### **Shower**

- Shower min 1000mm x 1000mm for ease of access - 2000mm x 1000 preferable
- Flush finish shower tray for ease of entry
- Fabric shower curtain easily opened and closed and allowing maximum space for chair
- Non-slip finish to tray

Two other design considerations to make space user friendly for wheelchair user to include

### **Floor**

- Slip resistant floor covering
- Drainage to internal gulley with floor gently sloped to gulley
- Gulley situated for easy access
- Stainless steel grid to gulley

### **Wash hand basin**

- Wall mounted WHB - no pedestal - to allow close access
- Provide 700mm clear knee space beneath WHB
- Lever taps fitted

### **WC**

- Spatula type lever handle fitted to transfer side of cistern to obviate reaching over to flush
- WC seat to finish 450 - 460mm above floor
- Vertical, horizontal and fold up grab rails as shown all grab rails to be 35mm diameter

### **Grab rails**

- Horizontal grab rails 700mm above floor, 600mm long and fitted 200mm from any corner
- Vertical grab rails starting 700mm above floor, 600mm long and of 35mm diameter
- Pull handle fitted to inside of door

### **Shower**

- Lever controls on shower for temperature and flow
- Flip-up seat fitted 450 above tray
- Shower head adjustable in height 1200 to 2200mm above tray
- Vertical and horizontal grab rails in shower cubicle

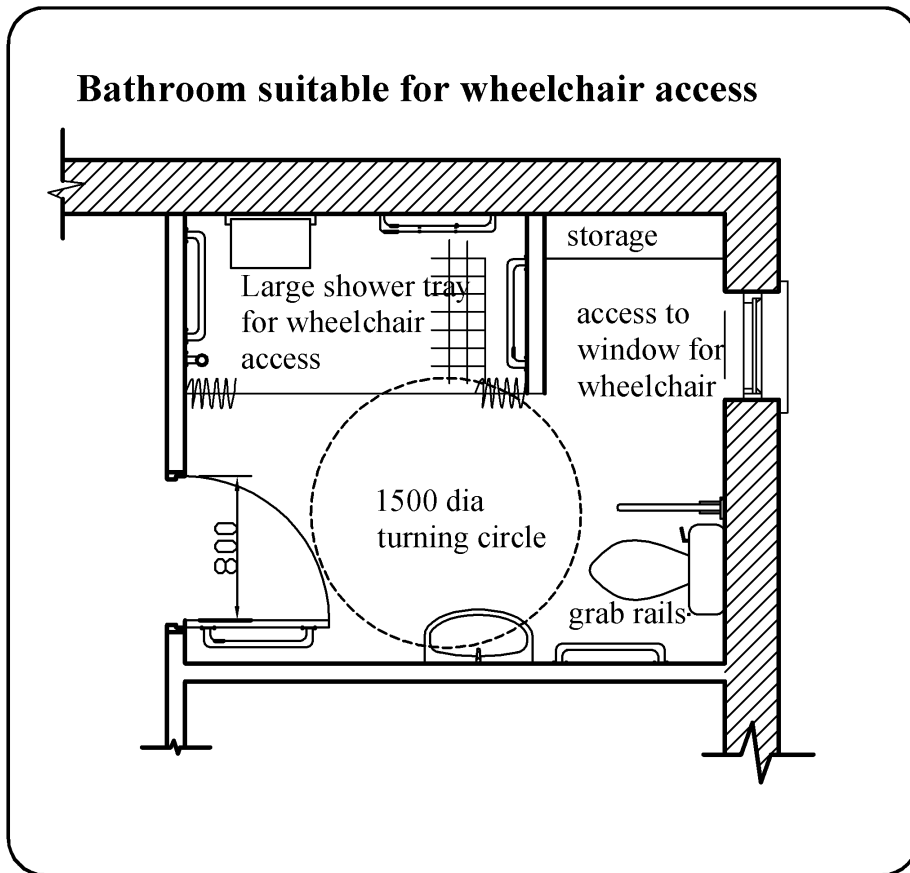

*Any other relevant data/details*

**Ceist 3 (a)**

Restoration of dwelling  
General design guidelines.

- Pitch of new roof to be same as original so as to retain proportion.
- Remove original natural slates and store for reuse.
- Do not clean exposed surface as patina will be lost
- Maintain original lap.
- Place best of original slates on the principal elevation.
- Source similar slates for rear or purchase new slates from original quarry.
- Retain and renew original rain water goods and reuse.
- Retain original sound fascia and soffit boards. Any new boards to have same profile as originals
- Combination of roof light windows and gable windows to provide light and ventilation to attic space

**3 (b)**

- Rigid insulation - 100mm urethane foam or equivalent to be friction fitted between rafters, collars and wall battens
- Alternative insulation types – natural wool, quilt or multi layer
- Rigid urethane foam 60mm – bonded to 12mm plaster board with vapour barrier to be fixed to underside of rafters, collars and wall battens
- Cavity in wall to be filled with insulation (pressure injected)
- Maintain 50mm air void to insulation between rafters
- Breathable felt
- Vent strip or other to soffit
- Floor joists 225x50mm at 400mm c/c.; C rafters 175x50mm at 400mm c/c. ; Collars 175x50mm at 400mm c/c ; Purlins 225x75mm. ; Ridge 225x37mm. ; Fascia 225x25mm; Soffit 100-200 x 12mm tg&v. ;Trimming 175 x 50mm. ;Bridging 225 x5 0mm. ; Wall battens 50 x 50mm @ 400mm c/c. ; Wall Plate 100 x 75mm. ; Galvanised wall plate straps
- Max height for roof lights 1800mm above floor level
- Ceiling height 2400mm and at least 50% of area of room measured at a height of 1.5metres above floor level.

**3 (c)**

- Roof lights to rear will not affect the visual integrity of the principal elevation and will help to maintain the original character of the building
- Roof lights in the roof plane to harmonise and be sympathetic with the original roof form
- Roof lights of the same width as the existing windows preferably - will allow maximum light and also demonstrate a sense of proportion
- Align roof lights with existing windows to maintain symmetry
- Windows in proportion to roof – visual harmony



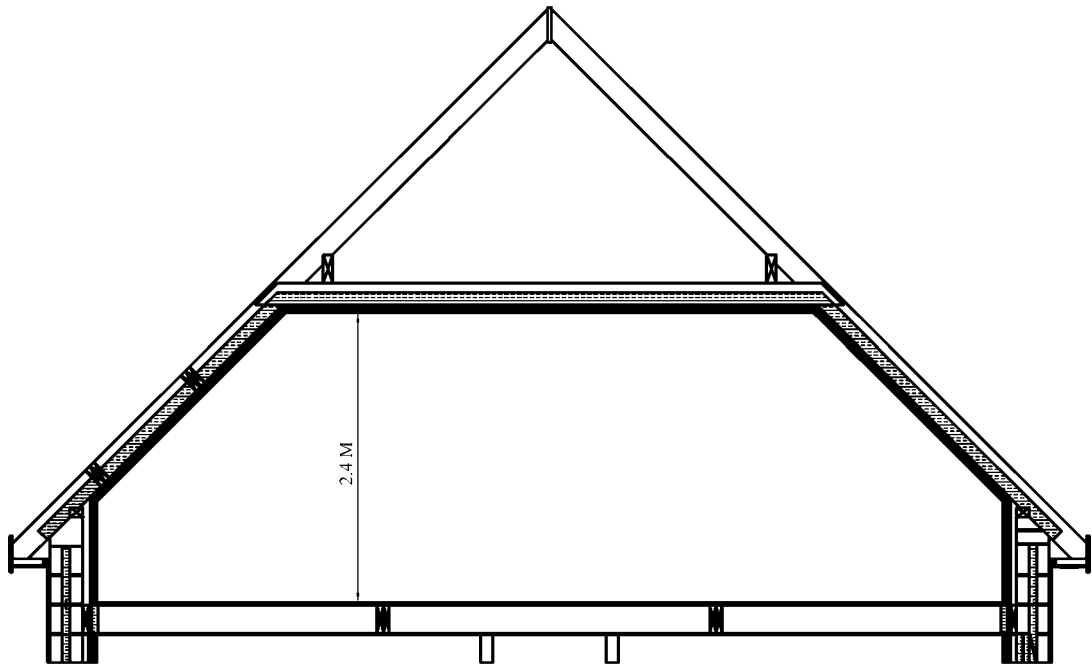

**Possible interpretation – Attic conversion (Walls carried through)**

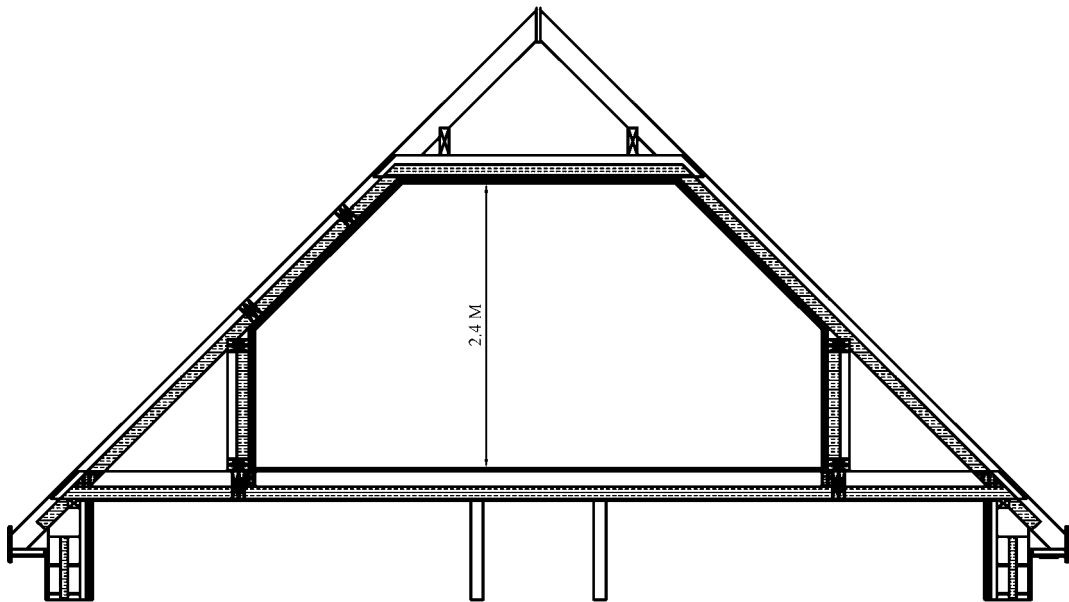

**Possible interpretation – Attic conversion**

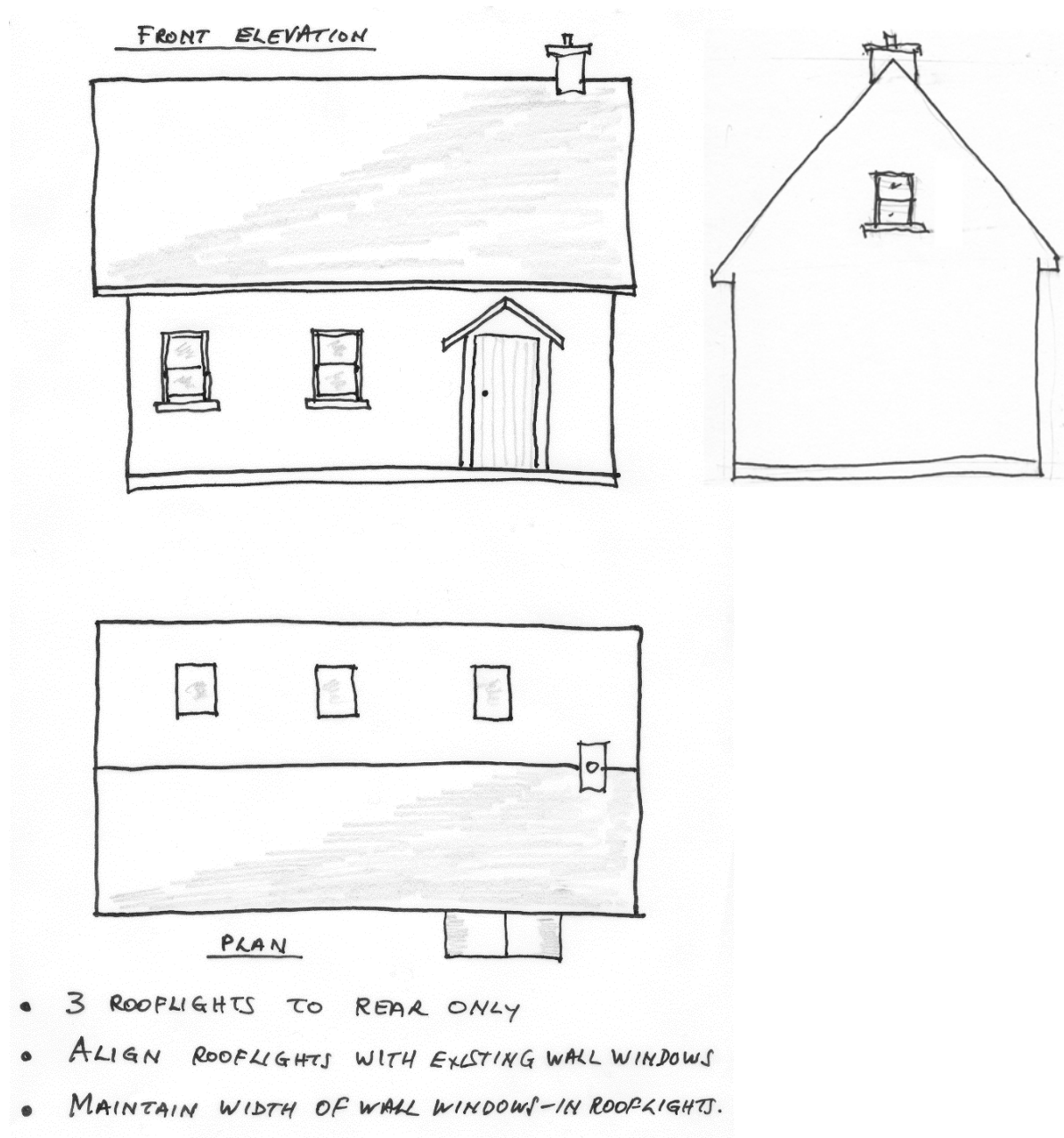

**CEIST 4**

**(a) (i)**

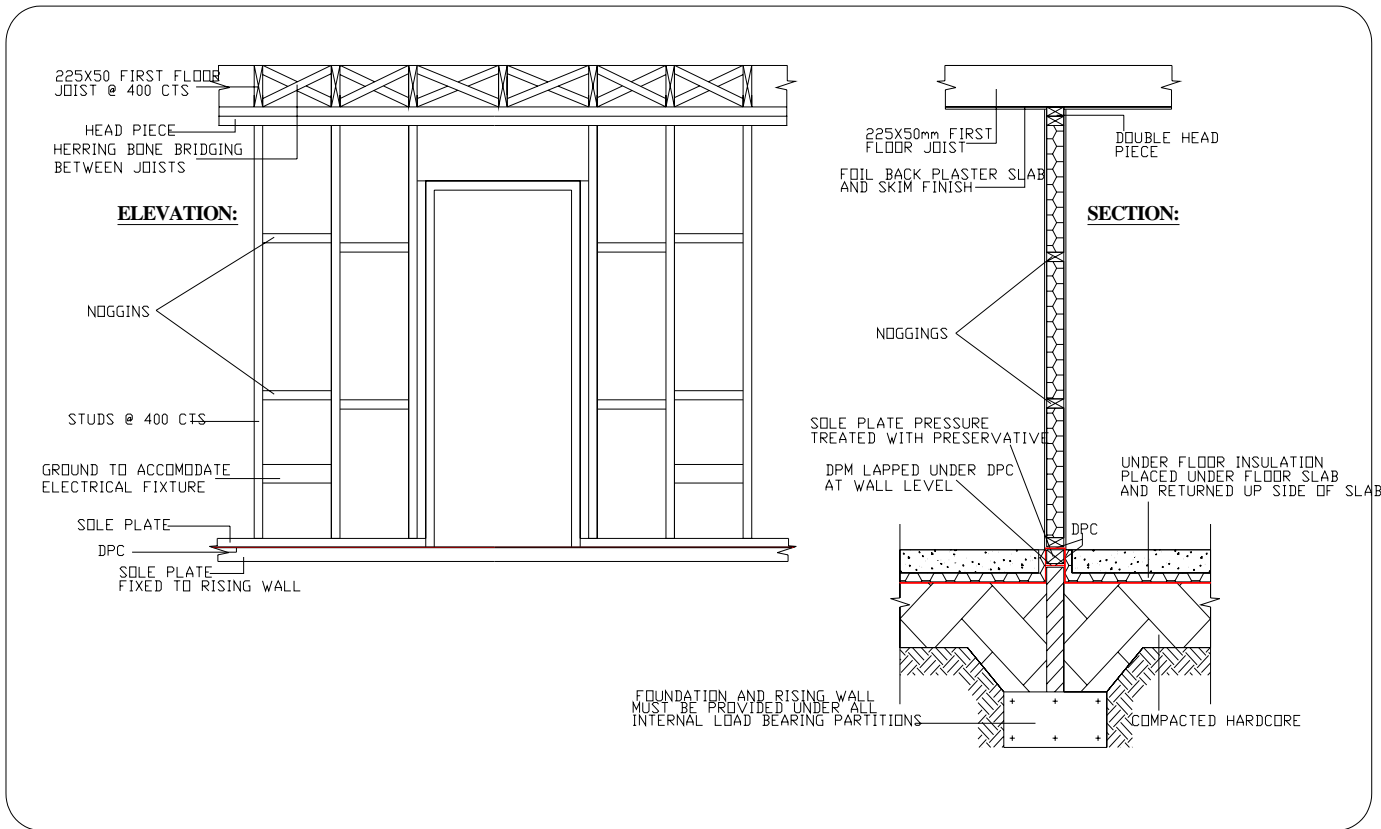

**Note:**  
 Foundation and rising wall under all load bearing partitions  
 Herring – bone strutting between joists  
 Plaster slabs fitted to bottom of studs for fireproofing

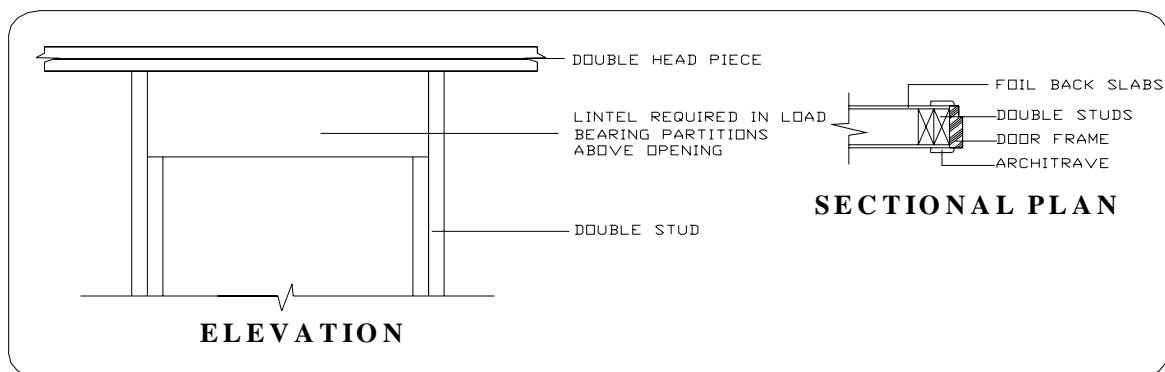

(ii)

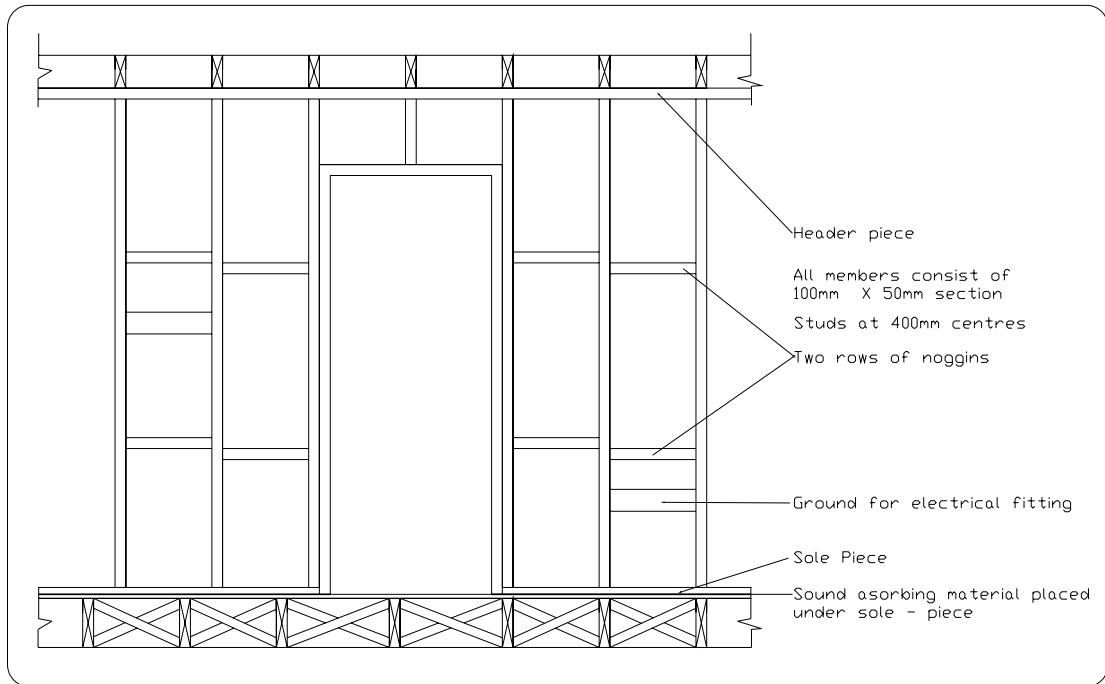

(b)

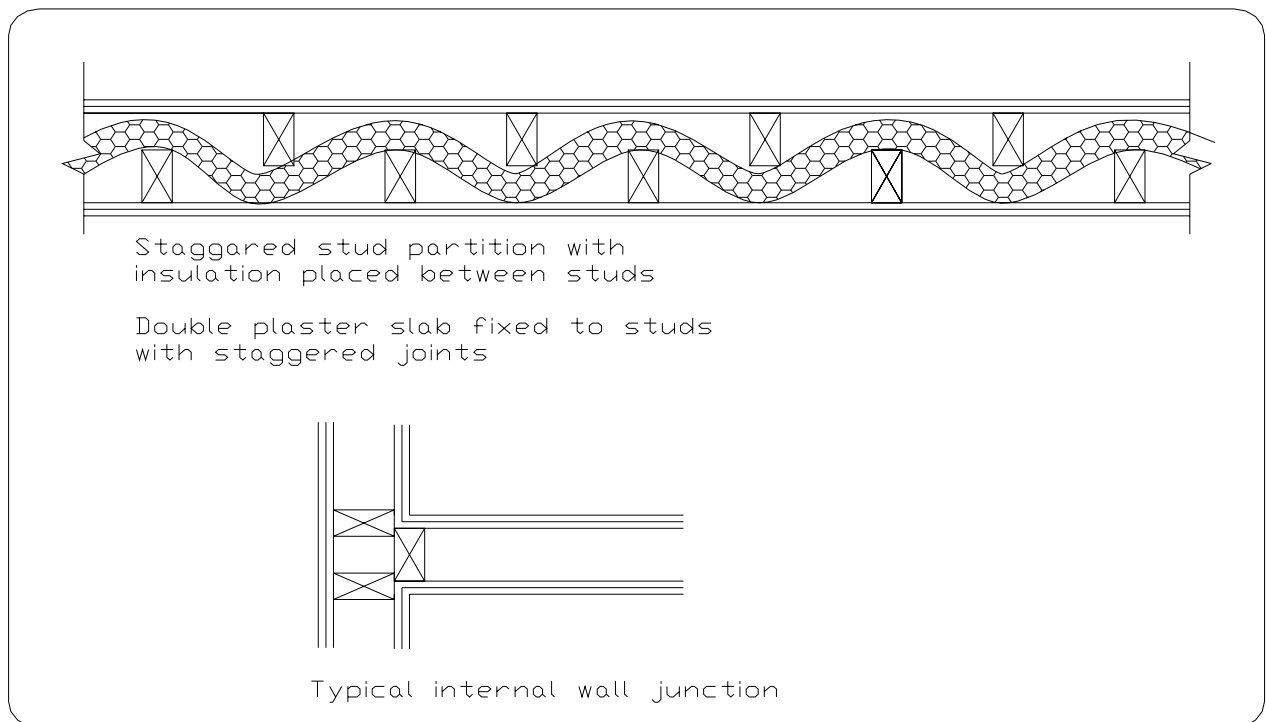

**Ceist 5 (a)**

<b>Component</b>	<b>Conductivity (K)</b>	<b>Resistivity (r = 1/k)</b>	<b>Thickness (T)</b>	<b>Resistance (R = T x R)</b>
Asphalt	---	1.250	0.020	0.025
Concrete screed	---	0.710	0.060	0.0426
Conc. Roof slab	---	0.690	0.175	0.1207
Int. plaster	---	2.170	0.015	0.0325
Int. surface res.	---			0.104
Ext. surface res.	---			0.413
			<b>Total resistance</b>	<b>0.738</b>
			<b>U-value</b>	<b>1.355 w/m<sup>2</sup>C</b>

**Overall Heat Loss** = U-value x Temp difference x Area of roof =

$$1.355 \times 21^{\circ} - 11^{\circ} \times 16\text{m} = 1.355 \times 10 \times 16 = 216.8 \text{ W per sec}$$

Design considerations for roofs:

1. Watertight
2. Dispose of rainwater
3. Durable
4. Structurally sound
5. Insulated
6. Aerated
7. Aesthetically pleasing

**Timber flat roof design**

(b)

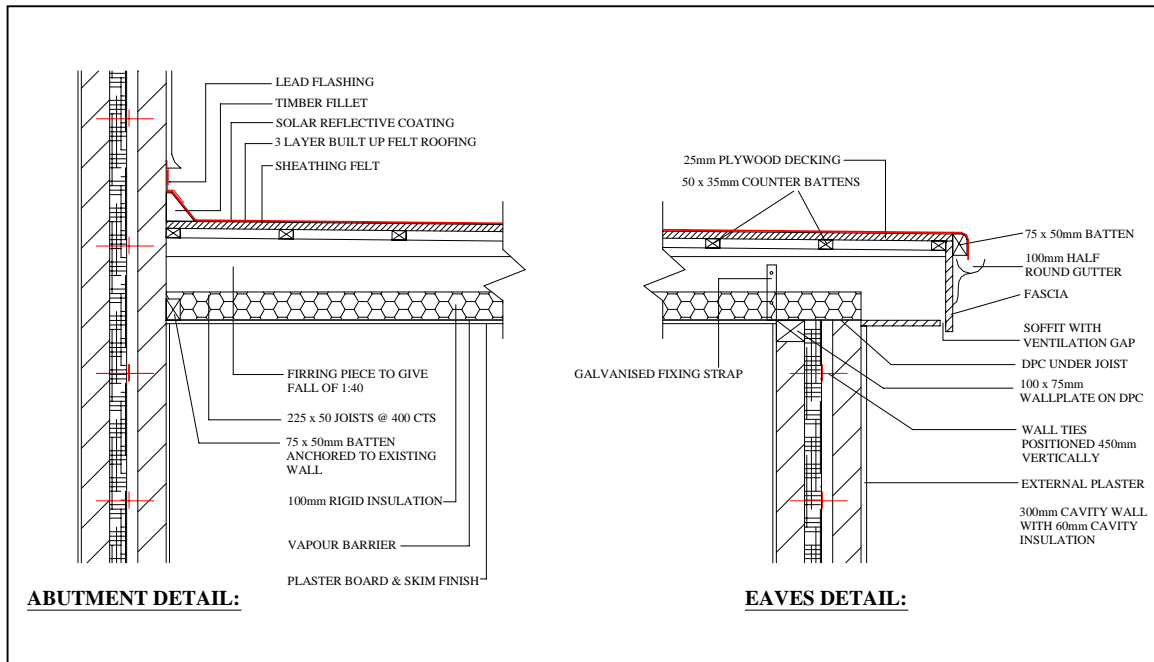

- Vapour barrier eliminates risk of insulation absorbing moisture, preventing an increase of moisture content in the wood.
- Prevents fungal growth such as *Merulius Lachrymans*. The fungal growth spreads rapidly in moist stagnant conditions.
- Vapour barriers include: 1000g Polythene, Aluminium Foil-back plaster slabs.
- Use good quality decking eg.: W.B.P. (Weather and Boil proof Plywood).
- Lay flat roofs so that the design fall is not less than 1 in 40.
- Ensure in design that there will be no ponding.
- Use kiln dried structural timber if possible, dried to 18% Moisture Content.

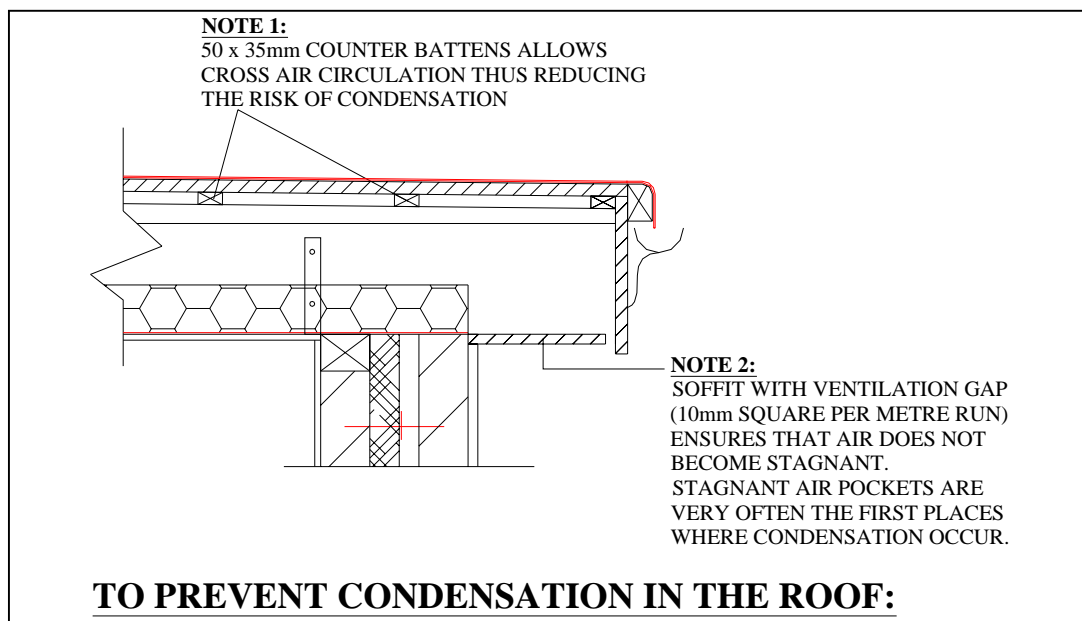

**Flat Roof Details**

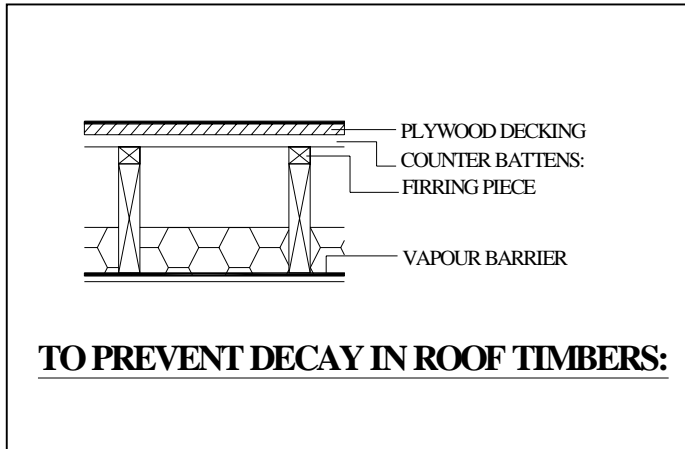

**Pitched Roof Details**

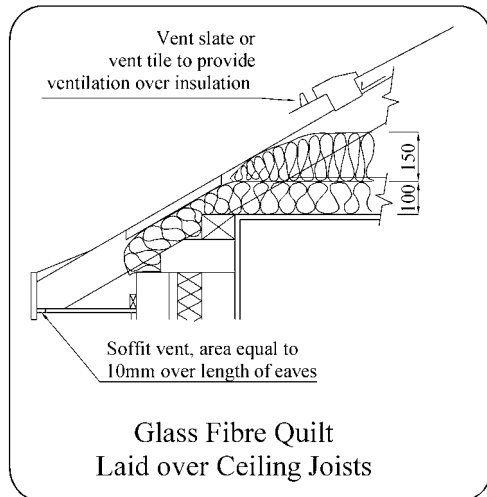
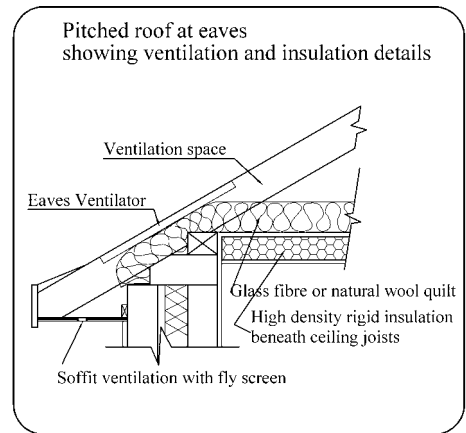

## Ceist 6

- 45 litre min header/expansion tank
- 230 litre min cold water storage tank
- 28mm min overflow warning pipe to discharge externally
- 15mm cold feed to indirect primary circuit.
- 28mm cold feed to cylinder
- 22mm cold feed to bathroom
- 15mm cold pipes to WC and WHB
- 22mm cold feed to bath
- 12mm fresh potable water to kitchen sink
- 12mm rising main  
Mains pipe in protective ducting through external wall entering building
- Heavy duty plastic water mains piping at least 760mm below ground level
- Cast iron or heavy duty plastic cover to stop valve/ water meter
- Water main

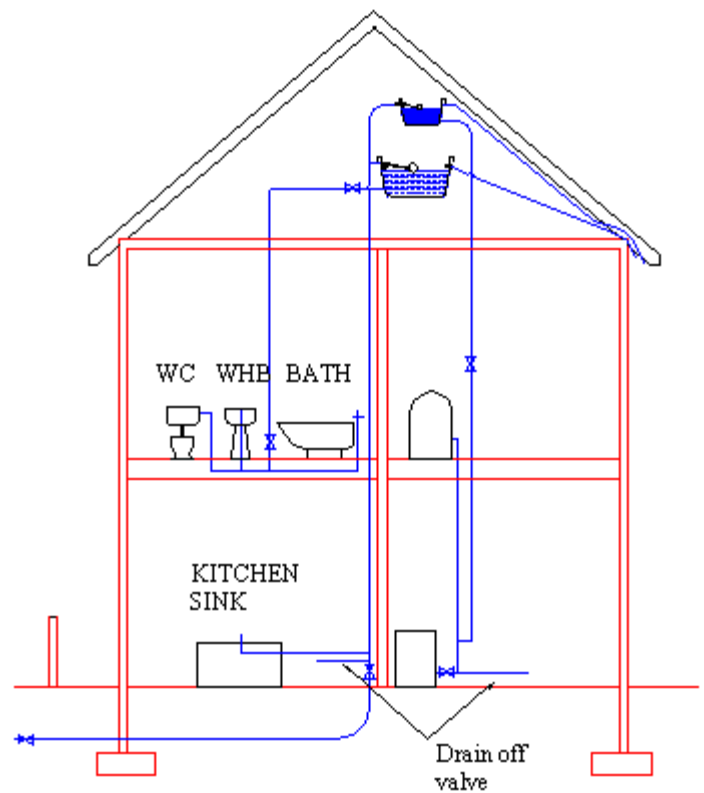

## Valves on supply

- For mains supply stop valve outside private boundary
- Stop valve and drain cock inside house
- Drain valve at sink
- Drain valve at boiler
- Stop valve on cold water to cylinder
- Stop valve on cold supply to bathroom
- Ball valve in water tanks

*Other valves as necessary*

## (c) Design Detail 1 showing overflow positioned 25mm min below inlet valve

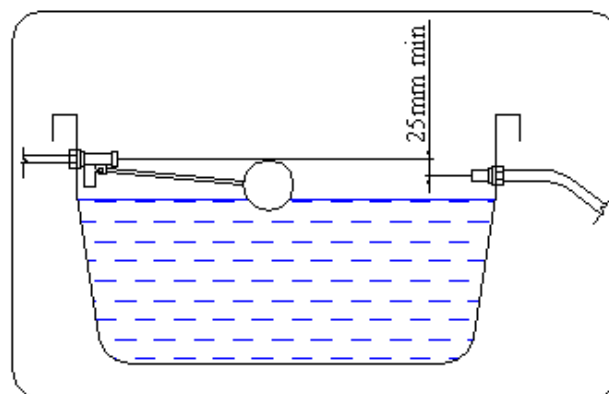



**(c) Design Detail 2**

- Ball cock and valve control water entering the storage tank.
- Water raises the ball float and closes the valve.

Overflow pipe allows the water to flow to the outside in the event of the valve failure, thus preventing flooding in the house.

Overflow pipe should be at least 25mm below the entry level of the incoming mains pipe.

Overflow pipe should be 28mm min diameter.

Overflow pipe must not discharge into gutters or down-pipes

Must discharge to open area

If a ball-cock/valve fails the overflow is a design essential.

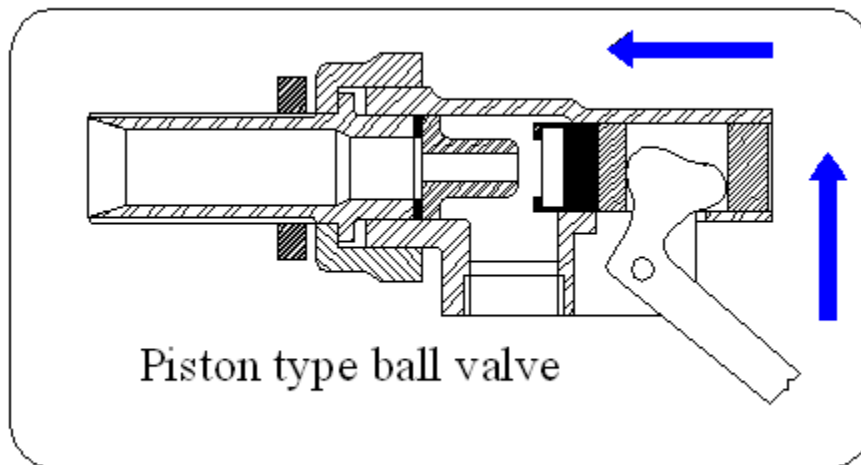
**Ball valve design details**

Ceist 7 (a)

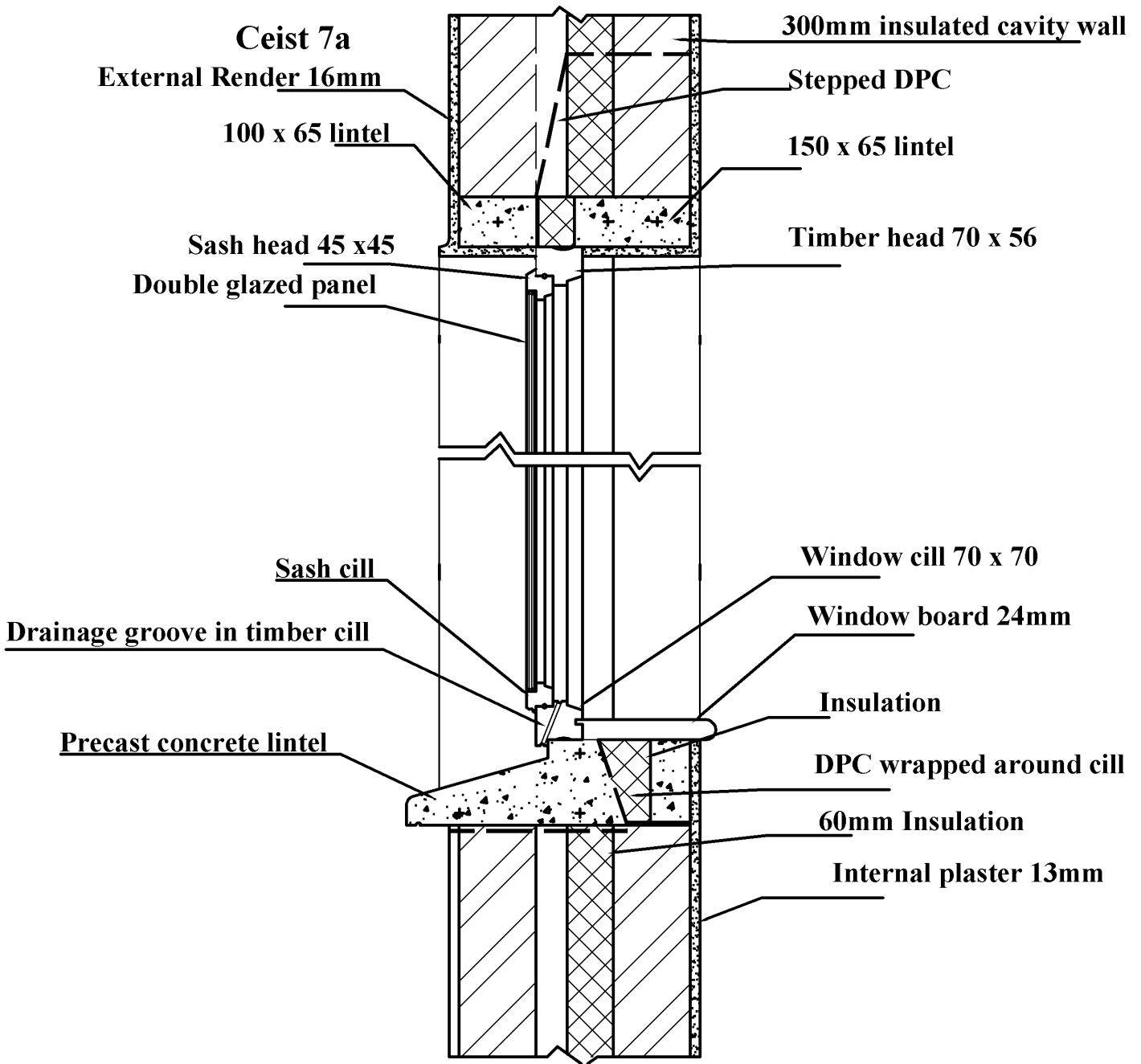

**Ceist 7 (b)**

To prevent formation of condensation

- Condensation can occur due to a lack of insulation
- Condensation occurs where thermal insulation is inadequate
- A cold bridge - a direct link between the inside and outside surfaces- can cause condensation
- The cold bridge effect reduces the temperature of the wall around the window (See Fig 1a)
- When warm moist air comes into contact with cold surfaces condensation occurs
- Insulating at the jamb (Fig 1b) eliminates cold bridging effect.

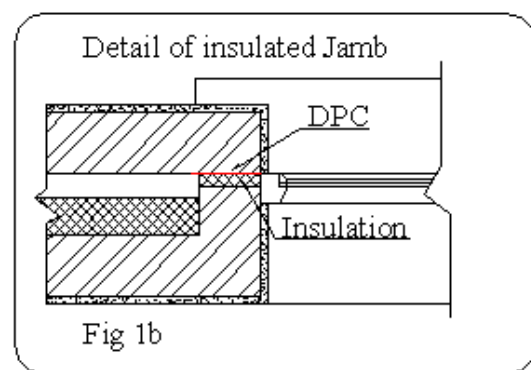
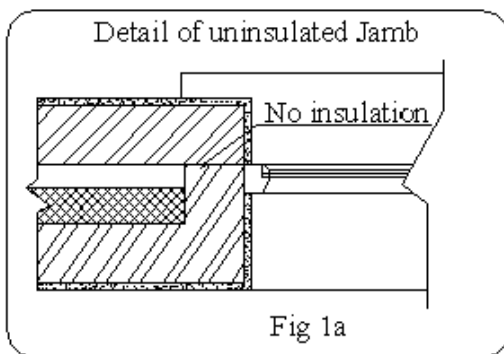

- Correct design detailing at window opening ensures that inner surfaces are kept warm thus reducing condensation
- Condensation can also occur in high moisture areas such as kitchens
- Bathrooms, kitchens and utility rooms can produce excessive humidity in the air
- Poor ventilation cause condensation problems
- Passive vent pipes installed to remove vapours from high moisture areas
- Mechanical ventilation may be used to remove the moisture laden air from such sources

Other methods of insulating the internal surfaces may be used to prevent condensation

- Fixing dry lining to the existing wall - plasterboard on battens with insulation in between, complete with vapour barrier.
- Plasterboard with integrated insulation, vapour barrier and reflective foil fixed to the wall using dabs of adhesive.

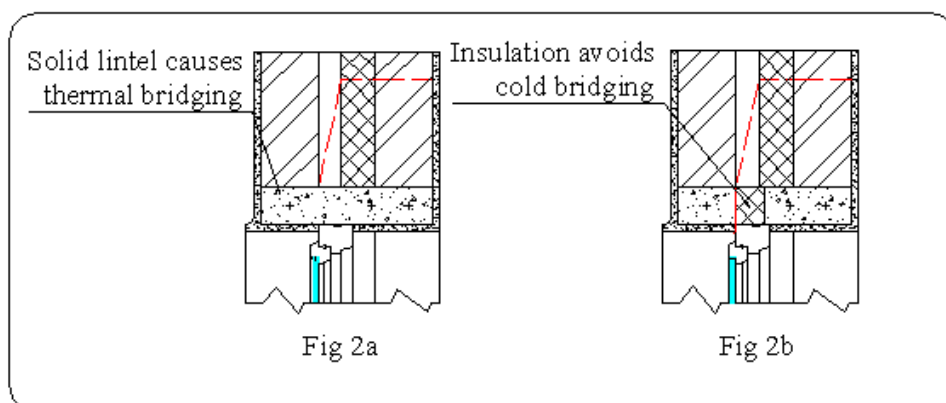

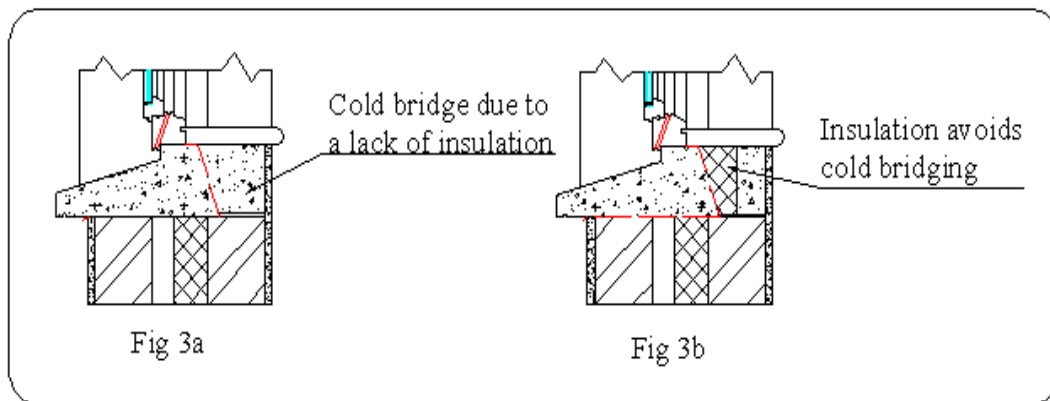

### Ceist 8 (a)

- Self venting
- Self cleansing
- Ease of inspection
- Simple and short runs with straight runs and slope to the main sewer or septic tank
- Pipes laid straight to even gradients from point to point such as access junctions, inspection chambers and manholes
- Changes in direction or gradients (such as drop manholes) to have adequate access points for inspection and clearing (rodding)
- All parts of the drainage system to be accessible for clearing blockages and inspection with no distance greater than 22metres from an access point
- Maximum distance between manholes to be 90 metres
- The drainage system to be vented through pipes up through the vent at the head of the main drain above the roof surface. This prevents siphonage at traps and releases odours
- uPVC most commonly used material for pipes and fittings. Pipes commonly in 6 metres lengths, light in weight, strong, easy to joint and do not break easily
- Other pipe materials are fibre cement, vitrified clay and concrete. Rigid pipes are more difficult to join, heavier to handle, come in shorter lengths and are more likely to leak
- 100 mm diameter pipes are usually used in domestic systems, laid to a gradient of 1 in 40 for 100mm pipes and 1 in 50 for 150mm pipes. The gradient or slope is important to carry the solids in the water/effluent. If the gradient is too steep the liquid may flow and not carry the solid and if the gradient is too low the velocity of the liquid might not be sufficient to carry the solids to the septic tank or public sewer. The system to be self venting and self cleansing.

Ceist 8 (a)

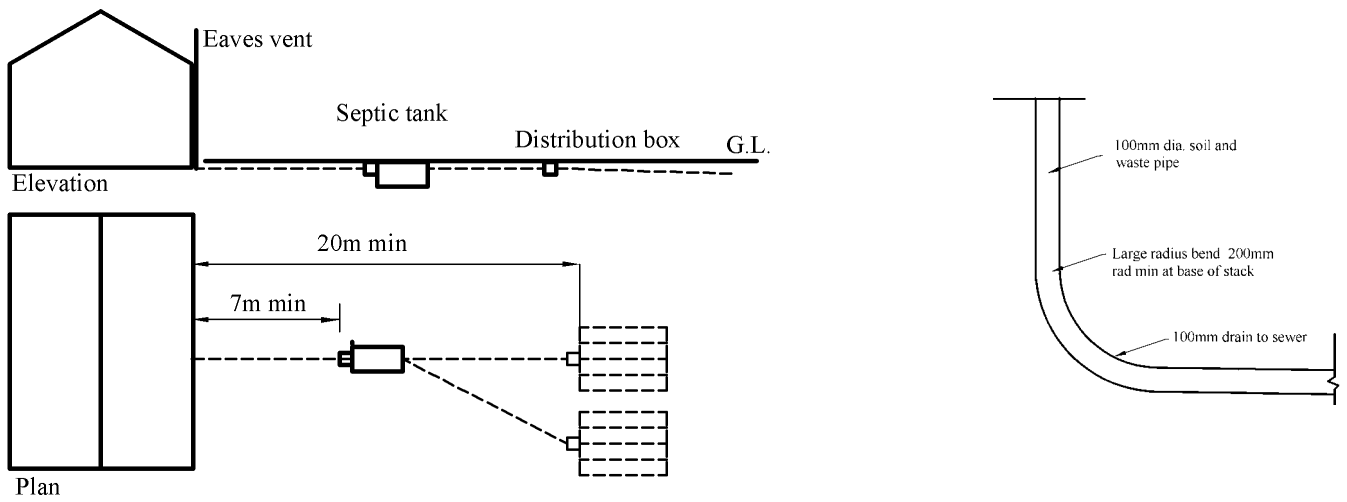

Ceist 8 (b)  
Section through backdrop manhole

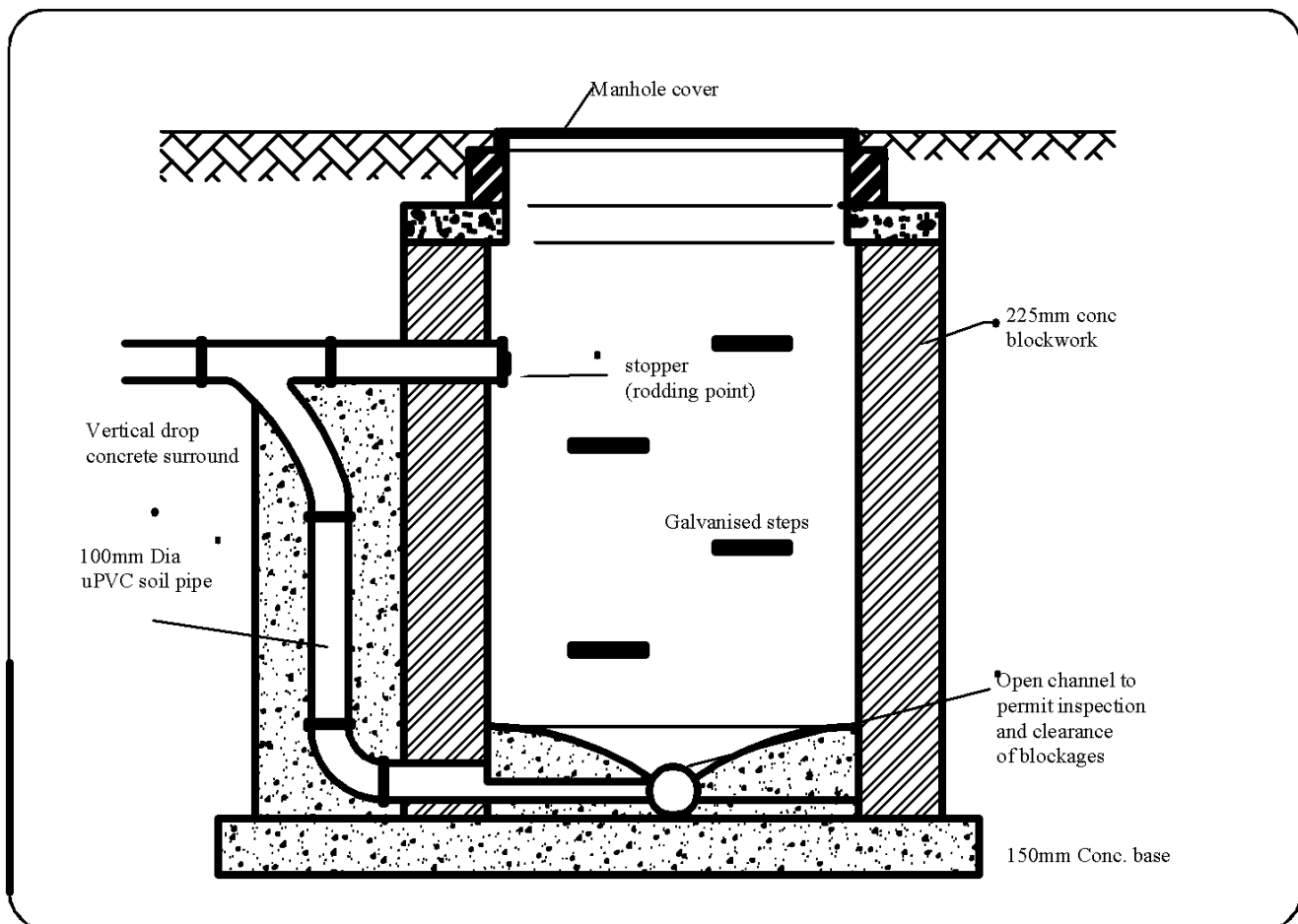

(a)

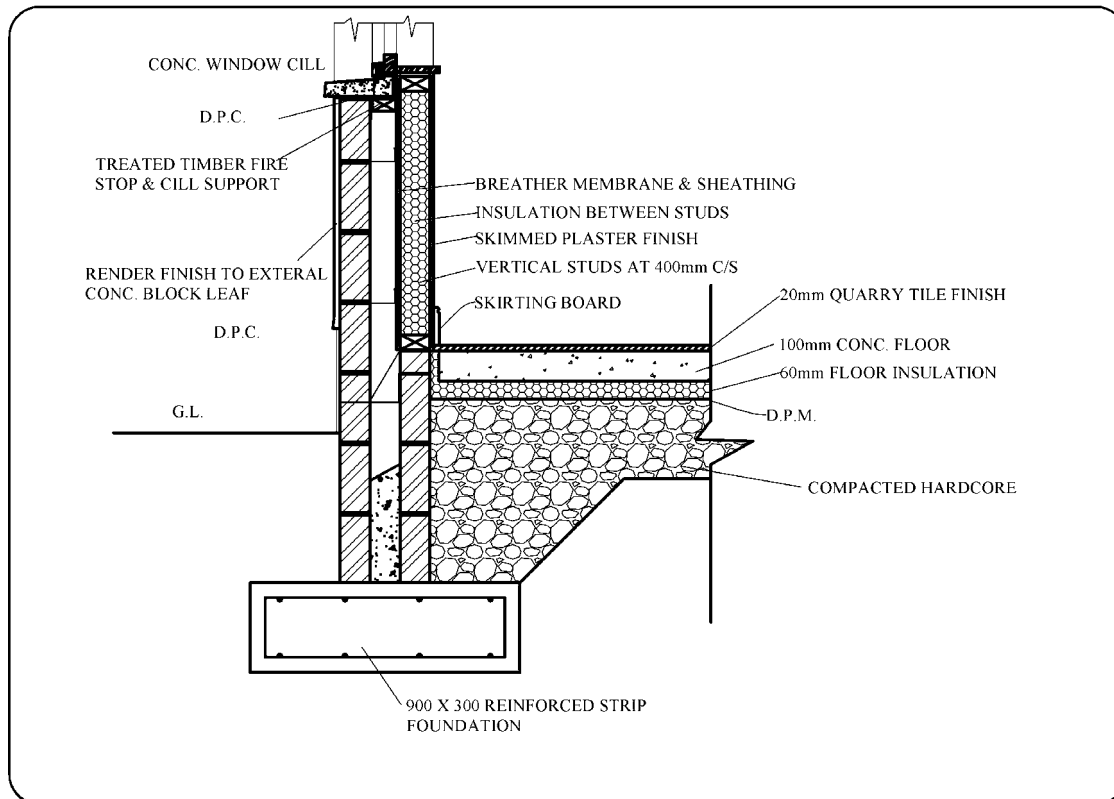
**(b) Advantages of timber frame construction**

- Timber is easily worked and of low self weight facilitating handling and erection
- Can be completed more quickly than an equivalent building involving the wet trades.
- Building has faster heat-up time
- Faster construction time allowing other trades work quickly
- Timber a renewable material
- Timber may be locally sourced
- Timber has low embodied energy
- Sustainable sources used when wood is sourced - plant a tree for each one felled

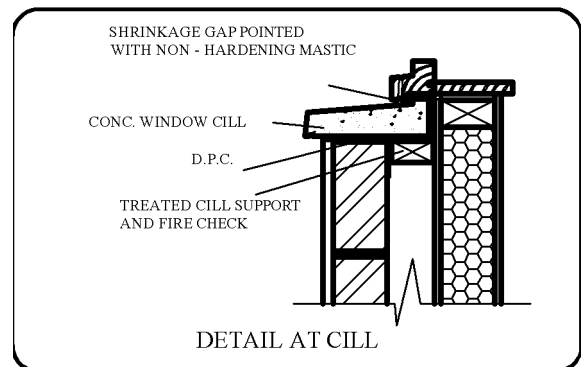
**Advantages of standard block wall construction**

- Thermal mass for heat retention
- Slower cooling down time
- Proper design for thermal efficiency
- High sound absorption properties - high mass
- Solid grounds for fixtures and fittings
- Long lifespan
- Solid, stable structures

**Ceist 10 (a)**

- Increased glazed areas maximise solar gain from the passive energy of the sun
- Advances in energy efficient glazing technology providing insulated low-emittance (low-e) coating to glass to reduce heat loss through the glazed areas
- Double and triple glazing to reduce heat loss through glazing and thus maximise passive solar gain
- Double glazing typically filled with inert gas giving a U-value of 0.35 for a standard window and 0.15 for a super low-e argon filled unit.
- Spaces between glass filled with argon or krypton gas as well as low conductance glass reduce heat loss
- Single glazed area requires four times more fossil fuel to maintain same temperature as double glazed, argon filled low-e insulated glazing of same area
- Glazed sunspaces allow for maximum natural light – reducing artificial light
- Sunspaces allow views of gardens and landscapes

**10(b)**

- Sunspaces facing south or at  $\pm 15^\circ$  to due south having the potential to maximise the passive energy of the sun
- Correct orientation and correct design can achieve 30% saving on fossil fuel energy

**10(c)**

- Full height double glazed windows maximise the surface area of glass exposed to the sun and thus maximise solar gain
- Short projecting eaves do not shade and allow to capture sun's rays - minimum shade important when the elevation of the mid summer sun at solar noon for Ireland is  $78^\circ$
- Height of windows allow maximum benefit in terms of solar gain during the winter months where the angle of the sun is considerably lower - at  $30^\circ$
- Glazing to have high U-value to trap and contain the sun's passive energy, especially in the winter months.
- The roof and floor must be well insulated to retain passive solar gain
- Thermal mass - thick insulated walls - inner leaf 225mm thick - , thick insulated floor slab with tiled surface to increase thermal mass and acting as heat sink to absorb solar heat, equalise temperature and prevent overheating
- Main living areas should adjoin sun space so that the heat gained can heat these areas and thus maximise benefit from solar energy
- Sun space must have facility to be isolated from main rooms to retain solar gain especially at night – doors that can be closed to reduce heat loss through glazing
- Heavy curtains/blinds/shutters to help heat retention in sun space at night time/winter time

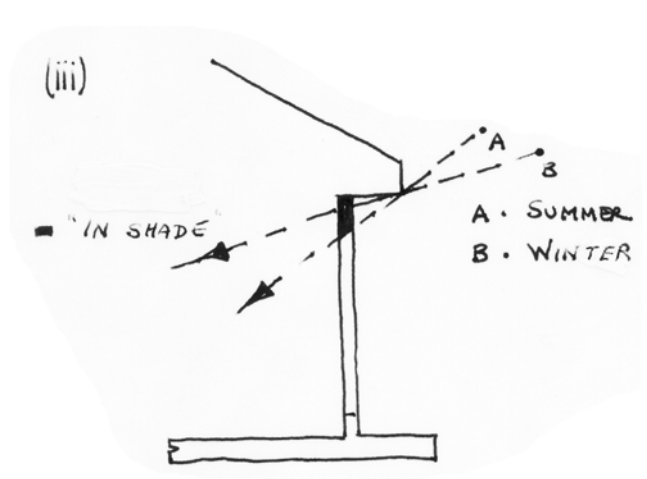
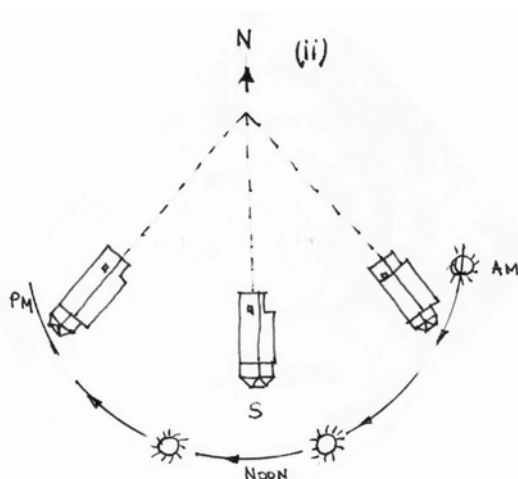

SKETCH TO SHOW ORIENTATION OF HOUSE AND SUNSPACE

**Ceist 10 (Alternative)**

**Centres of towns and cities have been subject to depopulation, with a consequent fraying of the urban fabric.....increasing separation between home, work and town centre have exacerbated the growth in private car transport**

**Points may include**

- Where we live as important as how we live – a properly functioning community has a sense of place, a community of friends and mutual support
- Fashionable to move to the suburbs...image of detached house in leafy suburbs seen as the idyll with a consequent loss of confidence in centre of town and city living
- Middle classes moved to the suburbs, centres of towns and cities seen as polluted and dirty – seen as more salubrious to live in the suburbs
- City centres associated with poverty, tenements, overcrowding, poor sanitation and not appropriate residential areas for the merchant classes who could afford better
- A paradigm of rural dwelling - a detached one-off house on its own site - low rise low density suburbs seen as the ideal
- The increasing urbanisation of Ireland from the 1960s onwards followed this model of urban development –consisting of detached or semi-detached houses with each house having its own piece of the country - back and front gardens
- This low density, low rise development generating the description suburban sprawl
- Leads to increasing separation between home, work and town centre
- Increased private car use has made roads unsafe for children to walk or cycle to school
- Parents drive their children to school from the suburbs leading to increased congestion on roadways, longer journey times and increased use of depleting fossil fuels
- This model of urban development is unsustainable and does not consider the energy needs of future generations
- Children consequently lose out on the opportunity to integrate exercise into their daily routine - leading to poor cardio-vascular fitness, obesity and a disinclination to exercise
- Depopulation of centres leads to closing of city centre facilities such as schools, playgrounds, libraries, leisure facilities and a consequent fraying of urban fabric necessary to sustain neighbourhoods and families
- Erosion of urban facilities and loss of public shared space militates against the development of a community spirit and community cohesion
- Urban decay leads to the loss of the traditional character of towns as contained spaces, built in the form of streets, terraces, squares and open areas
- City centres become associated with trading only, and when trading ceases these centres become forlorn and desolate in the absence of the vibrancy of a living community
- Only the ground floors of dwellings are used, leading to the decay of the fabric of the upper stories, leading eventually to the decay of the whole fabric of the building
- The concept of the family living over the shop has almost disappeared and with it an integrated way of life where both old and young could meet and walk to facilities
- Traditional town development has its own configuration of interconnecting streets and lanes as well as public areas such as parks and squares, giving continuity, directness and safety
- Children could walk in groups in visible safety to schools, playgrounds, church etc
- Concentration on suburban development leads to the neglect of the art of town planning and planning for sustainable communities with lower energy needs



**.... This has led to increased energy use and emissions of air pollutants and has militated against the effectiveness of public transport networks**

- **Increased car dependency – as a consequence of**
- Current models of suburban development are wasteful of space, materials and services
- Proper transport systems need population density, dispersed suburban development does not provide this critical mass necessary to sustain frequent bus and rail services...many suburbs have poor public transport services owing to the lack of this critical mass...leading to the isolation of many - especially the old and those with disabilities
- Depletion of the fossils fuels and consequent rise in price challenges us to re-envision the way we structure our dwellings and communities

**Three recommendations - such as**

- The challenge is to develop a deep cultural change - to break our dependence on the car, to transform the way we live and to revitalise the decline of centres of towns and cities
- Education needed to change of mindset, breaking the separateness mindset, to learn to live again in connectedness/communion with others
- Encourage the provision of a mixture of trading spaces and residential spaces, giving a living community, close to facilities such as schools, churches playing areas through financial assistance to first time occupants and buyers to live in town and city centres
- A need to rediscover and develop the charm of urban living where families will be attracted back to towns and villages and we should plan consciously for this end
- As fossil fuel become depleted, we will need to plan for more intentional lifestyles, close to amenities such as schools, churches, libraries, leisure centres, playing fields and save the fossil fuels
- Providing active social areas such as dedicated safe play areas for children
- Provide proper supervision for these areas so that they are at all times safe for both children and elders
- Limit the effect of the motor car on urban communities by providing dedicated parking areas, pedestrianised town centres, with dedicated areas for family relaxation
- Provide cycle lanes and green walking routes especially to schools for safety of children
- Plan mixed dwellings in town and city centres for old, middle age and young, many old people return to the security of planned urban living and proximity to facilities
- Increase the facilities for positive social interactions and thus build a community sense
- Provide incentives for people who buy houses in urban areas, such as for first time buyers
- Plan for apartments of adequate floor area to accommodate families in town and city centres
- Provide incentive for smaller trading outlets, family businesses, mixed living and trading
- Develop model urban areas, where a new model can be observed and appreciated
- Raise awareness of need to arrest decay of towns and cities.

***Any other relevant points***

Three recommendations to planning authority - supported by cogent and relevant argument.



**Coimisiún na Scrúduithe Stáit**  
*State Examinations Commission*

Scrúdú Ardteistiméireachta 2005

*Staidéar Foirgníochta*  
*Teoiric – Ardleibhéal*

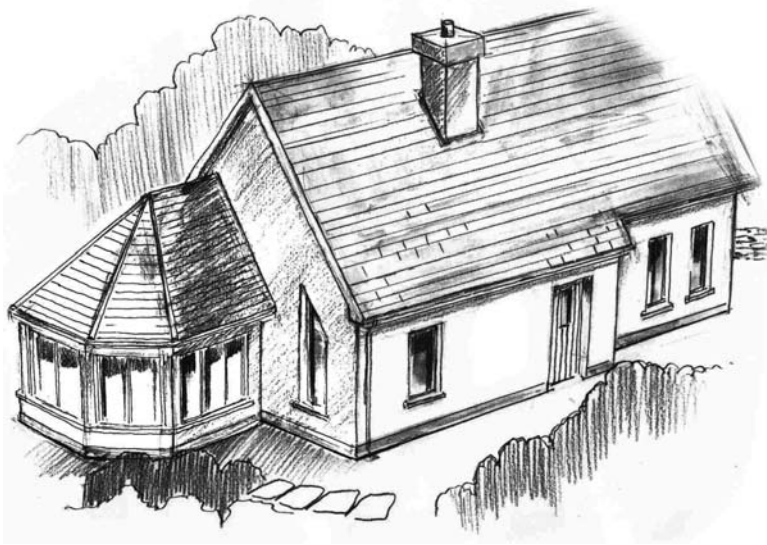

*Construction Studies*  
*Theory – Higher Level*

*SCÉIM MHARCÁLA*  
*Marking Scheme*

**CEIST 1**

<b>PERFORMANCE CRITERIA</b>	<b>MAXIMUM MARK</b>
<i>Any 4 points for timber floor and 4 points for solid floor 5 marks for scale and draughting (4marks for drawing and 1mark for drafting and annotation.)</i>	
900 x 300 reinforced foundation	<b>5</b>
300mm insulated cavity block wall	
Floors	<b>5</b>
Concrete floor tile on 75mm concrete screed	<b>5</b>
50mm high density insulation on radon barrier	<b>5</b>
200mm sub floor	<b>5</b>
Hardcore min 150mm with sand blinding	<b>5</b>
25mm t & g flooring	<b>5</b>
Joists @400 centres	<b>5</b>
Minimum 150mm fibreglass or equivalent urethane board 100 x 50mm wall plate on DPC	<b>5</b>
100mm brick/sleeper wall at no more than 1.2M centres	<b>5</b>
150mm sub floor	<b>5</b>
150mm blinding with sand	
Scale	<b>5</b>
<b>(b) 5 marks for each of 2 applicable design details</b>	
Design detail 1 - Vent /sleeve/ducting	<b>10</b>
<b>TOTAL</b>	<b>60</b>

**CEIST 2**

PERFORMANCE CRITERIA	MAXIMUM MARK
<b>(a) <i>Three areas in a dwelling house that need specific consideration to be detailed</i></b>	
Area 1: Notes Sketch	<b>5</b> <b>5</b>
Area 2: Notes Sketch	<b>5</b> <b>5</b>
Area 3: Notes Sketch	<b>5</b> <b>5</b>
<b>(b) <i>Three specific design considerations for one selected area</i></b>	
Design Detail 1: Notes Sketch	<b>5</b> <b>5</b>
Design Detail 2: Notes Sketch	<b>5</b> <b>5</b>
Design Detail 3 Notes Sketch	<b>5</b> <b>5</b>
<b>Total</b>	<b>60</b>

**CEIST 3**

<b>PERFORMANCE CRITERIA</b>	<b>MAXIMUM MARK</b>
<b>(a) Any 8 points x 5 marks each</b>	
Rafters	<b>5</b>
Flooring joists	<b>5</b>
Collar-ties	<b>5</b>
Studding next to eaves, height	<b>5</b>
Ceiling height	<b>5</b>
Wall plate	<b>5</b>
Ridge board	<b>5</b>
Flooring/sheeting	<b>5</b>
Stud-walls and ceiling finish	<b>5</b>
Roofing material and method	
Insulation	
<b>(b)</b>	
<i>Method 1, for providing natural light into the bedrooms</i> Discuss and sketch the options available	<b>10</b>
Advantage 1, for method given	<b>5</b>
Advantage 2, for method given	<b>5</b>
Total	<b>60</b>

**CEIST 4 (A) (I)**

<b>PERFORMANCE CRITERIA</b>	<b>MAXIMUM MARK</b>
<b>(a) Any 5 points x 4 marks</b>	
Floor joists @400 centres	<b>4</b>
Double header	<b>4</b>
Vertical studs	<b>4</b>
Noggings	<b>4</b>
Sole plates two	<b>4</b>
DPM / Radon barrier	<b>4</b>
Load bearing wall from foundation to partition	<b>4</b>
Comparison between both partition types	<b>4</b>
<b>a (ii)</b>	<b>4</b>
Ceiling joists	<b>4</b>
Header	<b>4</b>
Vertical Studs (100 x 50)	<b>4</b>
Noggings	<b>4</b>
Sole plate	
Bridging	
<b>(b) 5 marks for notes, 5 marks for each sketch</b>	
Design Detail 1	
Notes	<b>5</b>
Sketch	<b>5</b>
Design Detail 2	
Notes	<b>5</b>
Sketch	<b>5</b>
<b>Total</b>	<b>60</b>

**CEIST 5**

<b>PERFORMANCE CRITERIA</b>	<b>MAXIMUM MARK</b>
<b><i>(a) Ten points x 3 marks for each point</i></b>	
Correct Tabulation	<b>3</b>
Asphalt (Resistance)	<b>3</b>
Concrete screed	<b>3</b>
Concrete roof slab	<b>3</b>
Internal plaster	<b>3</b>
Internal /external surface resistance	<b>3</b>
Total resistance	<b>3</b>
U Value	<b>3</b>
Overall heat loss	<b>6</b>
<b><i>(b) Any 2 design considerations – 6 marks for notes and 9 marks for sketches</i></b>	
Consideration 1	
Notes	<b>6</b>
Sketches	<b>9</b>
Consideration 2	
Notes	<b>6</b>
Sketches	<b>9</b>
<b>Total</b>	<b>60</b>

**CEIST 6**

<b>PERFORMANCE CRITERIA</b>	<b>MAXIMUM MARK</b>
<b>(a) Any 5 x 3 marks each</b>	
Pipe arrangement, two- storey house	<b>3</b>
Rising mains from outside house	<b>3</b>
Supply to kitchen sink and tanks	<b>3</b>
Overflows/lagging/insulation	<b>3</b>
Piping to bathroom from storage tank	<b>3</b>
Piping to cylinder from storage tank	<b>3</b>
Supply pipe to bath	<b>3</b>
Piping to bath and to either (or both) WHB and WC	<b>3</b>
<b>(b) Any 3 pipes sizes correctly shown 3 x 3 marks each.</b>	
28mm cold feed to cylinder & overflow	<b>3</b>
22mm to Bathroom & Bath	<b>3</b>
15mm to WC & WHB and indirect primary circuit	<b>3</b>
12mm rising main and to kitchen sink - any 3 valves correctly shown 3x4 marks each	<b>3</b>
<b>Valves 3 Valves x 4 marks each</b>	
Gate valve outside house	<b>4</b>
Stop cock inside house	<b>4</b>
Stop and drain valve inside house	<b>4</b>
Ballcock and valve in tanks	<b>4</b>
Stopvalve on supply to cylinder	<b>4</b>
Stopvalve on supply to bathroom	<b>4</b>
<b>(c) Any 2 design details shown – 4 marks for notes and 4 marks for sketch</b>	
<b>Design Detail 1</b>	
Notes	<b>6</b>
Sketch	<b>6</b>
<b>Design Detail 2</b>	
Notes	<b>6</b>
Sketch	<b>6</b>
<b>Total</b>	<b>60</b>



**CEIST 7**

<b>PERFORMANCE CRITERIA</b>	<b>MAXIMUM MARK</b>
<b>(a) 7 features x 5 marks each: 5 marks for scale and draughting</b>	
Cavity wall and insulation	<b>5</b>
Stepped DPC	<b>5</b>
Lintels	<b>5</b>
Window head	<b>5</b>
Sash and glass	<b>5</b>
Window cill	<b>5</b>
Window cill	<b>5</b>
Concrete cill	<b>5</b>
DPC under and up at ends	<b>5</b>
Insulation at back of concrete cill	<b>5</b>
Concrete back fill / window board	
Wall ties & plaster on outside and inside	
<b><i>Scale and draughting</i></b>	<b>5</b>
<b>(b) Any 2 details shown, 5 marks for notes and 5 marks for sketch</b>	
Design Detail No. 1	
Sketch	<b>5</b>
Note	<b>5</b>
Design Detail No. 2	
Sketch	<b>5</b>
Note	<b>5</b>
<b>Total</b>	<b>60</b>

**CEIST 8**

<b>PERFORMANCE CRITERIA</b>	<b>MAXIMUM MARK</b>
<b><i>(a) Any 3 design details- 5 marks for notes and 5 marks for sketch</i></b>	
Consideration No. 1	
Notes	<b>5</b>
Sketch	<b>5</b>
Consideration No. 2	
Notes	<b>5</b>
Sketch	<b>5</b>
Consideration No. 3	
Notes	<b>5</b>
Sketch	<b>5</b>
<b><i>(b) Any 6 design details to include:</i></b>	
Back-drop manhole/foundation and wall thickness and to scale	<b>5</b>
Concept of backdrop	<b>5</b>
Depth to invert level 1800mm	<b>5</b>
Steps	<b>5</b>
Rodding eye	<b>5</b>
Manhole cover and seal	<b>5</b>
<i>Benching, slope, channel</i>	<b>5</b>
<b>Total</b>	<b>60</b>

**CEIST 9**

<b>PERFORMANCE CRITERIA</b>	<b>MAXIMUM MARK</b>
<b>(a)</b> <i>Any 7 points x 5 marks each: 5 marks for scale and draughting</i>	
Concrete window cill (900mm) above floor level	<b>5</b>
DPC under cill	<b>5</b>
Treated cill support/fire check	<b>5</b>
Window and window board / timber stud wall, studs at 400 c/s	<b>5</b>
100mm Concrete block outer wall	<b>5</b>
Cavity and ties to inner stud wall	<b>5</b>
Soleplate/panel anchored to base	<b>5</b>
Breather membrane and sheeting	<b>5</b>
Insulation between studs	
Vapour barrier	
External and internal finishes	
<b>20mm quarry tiles</b> <b>100mm concrete floor</b>	<b>5</b>
<b>60mm floor insulation</b>	
<b>DPM</b>	
<b>Compacted hardcore</b>	
<b>Cavity fill</b>	
<b>900mm x 300mm reinforced foundation</b>	<b>5</b>
<b>Scale and draughting</b>	
<b>(b)</b>	
<b>Timber Frame Housing</b>	<b>5</b>
Advantage No. 1	<b>5</b>
Advantage No. 2	
<b>Concrete Block Housing</b>	<b>5</b>
Advantage No. 1	<b>5</b>
Advantage No. 2	
<b>Total</b>	<b>60</b>

## Ceist 10

PERFORMANCE CRITERIA	MAXIMUM MARK
<b>(a) 3 advantages, 4 marks per advantage</b>	
Advantage No. 1	<b>4</b>
Advantage No. 2	<b>4</b>
Advantage No. 3	<b>4</b>
<b>(b) 6 marks for notes, 6 marks for sketch</b>	
<i>Reason No. 1</i>	<b>6</b>
Notes	<b>6</b>
Sketch	<b>6</b>
<i>Reason No. 2</i>	<b>6</b>
Notes	<b>6</b>
Sketch	<b>6</b>
<b>(c) 6 marks for notes, 6 marks for sketch</b>	
<i>Design Consideration No. 1</i>	<b>6</b>
Notes	<b>6</b>
<i>Sketch</i>	<b>6</b>
<i>Design Consideration No. 2</i>	<b>6</b>
Notes	<b>6</b>
Sketch	<b>6</b>
Total	<b>60</b>

**CEIST 10 (ALTERNATIVE)**

<b>PERFORMANCE CRITERIA</b>	<b>MAXIMUM MARK</b>
<i>Any 5 points supported by analysis and discussion: 6 marks each</i>	
Analysis and discussion of each statement	<b>6</b> <b>6</b> <b>6</b> <b>6</b> <b>6</b>
Recommendation 1 supported by discussion	<b>10</b>
Recommendation 2 supported by discussion	<b>10</b>
Recommendation 3 supported by discussion	<b>10</b>
Total	<b>60</b>



**Coimisiún na Scrúduithe Stáit**  
***State Examinations Commission***

---

***Scrúdú Ardteistiméireachta 2005***  
***Leaving Certificate Examination 2005***

***Scéim Mharcála***  
***Marking Scheme***  
***(150 marc)***

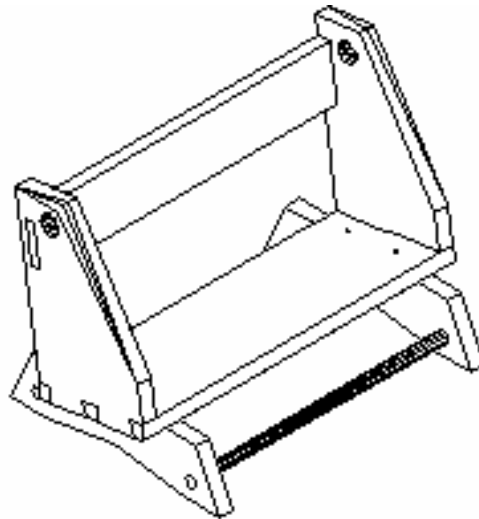

***Staidéar Foirgníochta***  
***Triail Phraticiúil***

***Construction Studies***  
***Practical Test***

# Construction Studies 2005

## Marking Scheme - Practical Test

**Note:**

The artefact is to be hand produced by candidates without the assistance of machinery except that of a battery powered screwdriver - which is allowed.

Where there is evidence of the use of machinery in the test for a particular procedure a penalty applies. Component is marked out of 50% of the marks available for that procedure.

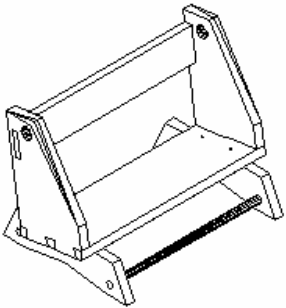
	<b>A</b>	<b>OVERALL ASSEMBLY</b>	<b>Marks</b>
	1	Overall quality of assembled artifact	8
	2	Dowels located and fitted correctly  <i>(4 x 1 marks)</i>	4
	3	Edge of base – (i) design (ii) shaping  <i>(2 x 4 marks)</i>	8
	<b>Total</b>		<b>20</b>

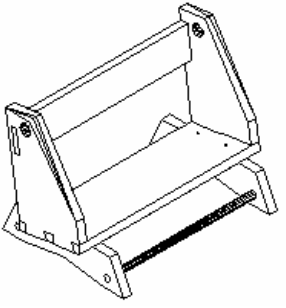
	<b>B</b>	<b>MARKING OUT</b>	<b>Marks</b>
	1	Right support  <i>(6 x 1 mark)</i>	6
	2	Left support  <i>(6 x 1 mark)</i>	6
	3	Base  <i>(4 x 2 marks)</i>	8
	4	Right side	10
	5	Left side	10
	6	Back rail  <i>(2 x 2 marks)</i>	4
	<b>Total</b>		<b>44</b>

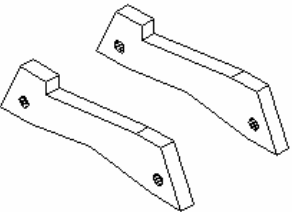
<b>SUPPORTS</b>	<b>C</b>	<b>PROCESSING</b>	<b>Marks</b>
	1	Shaping sloped ends  <i>(4 x 1 mark)</i>	4
	2	Shaping bottom  <i>(4 x 1 mark)</i>	4
	3	Shaping top - long slope - short cut <i>(2 x 3 marks)</i> <i>(2 x 1 mark)</i>	8
	<b>Total</b>		<b>16</b>

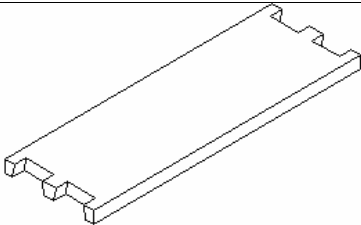
<b>BASE</b>	<b>D</b>	<b>PROCESSING</b>	<b>Marks</b>
	1	Four dovetail pins - vertical sawing <i>(4 x 2 marks)</i>	8
		Cutting across grain <i>(4 x 2 marks)</i>	8
		<b>Total</b>	<b>16</b>

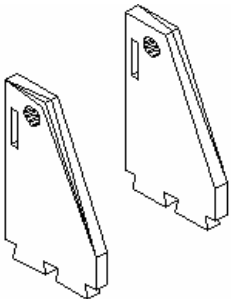
<b>TWO SIDES</b>	<b>E</b>	<b>PROCESSING</b>	<b>Marks</b>
	1	Four dovetails – each dovetail four marks <i>(4 x 4 marks)</i>	16
	2	Shaping of sloping edges <i>(2 x 2 marks)</i>	4
	3	Forming four chamfers <i>(4 x 2 marks)</i>	8
	4	Two mortices <i>(2 x 4 marks)</i>	8
	5	Drilling holes	2
		<b>Total</b>	<b>38</b>

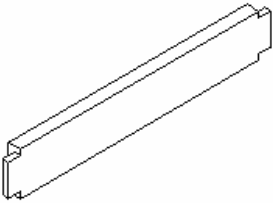
<b>BACK RAIL</b>	<b>F</b>	<b>PROCESSING</b>	<b>Marks</b>
	1	Two tenons – each tenon 6 marks <i>(2 x 6 marks)</i>	12
		<b>Total</b>	<b>12</b>

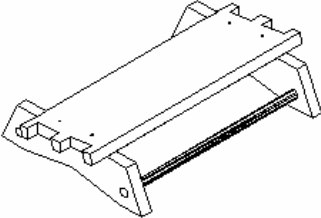
<b>ASSEMBLY</b>	<b>G</b>	<b>PROCESSING</b>	<b>Marks</b>
	1	Drilling and fitting 4 screws <i>(4 x 1 mark)</i>	4
		<b>Total</b>	<b>4</b>





**Leaving Certificate Examination 2005**

***Construction Studies***

***School Assessment of Candidates' Practical Coursework***

Name of Candidate: ..... Examination Number:

- Type of Project:
- |   |   |
|---|---|
| <input type="checkbox"/> Practical Craft                | <input type="checkbox"/> Building Science |
| <input type="checkbox"/> Written/Drawn with Scale Model | <input type="checkbox"/> Composite        |

	<b>Marking Scheme</b>	<b>Maximum Marks</b>	<b>Marks Awarded</b>
<b>A</b>	<b>Planning of Project</b> <ul style="list-style-type: none"> <li>• Ability to design an appropriate plan of procedure</li> <li>• Evidence of research</li> <li>• Preparation of working drawings/use of models as graphic aids</li> </ul> <p style="text-align: right;"><b>Subtotal</b></p>	<b>30</b>	
<b>B</b>	<b>Report Writing</b> <ul style="list-style-type: none"> <li>• Design folio detailing planning, execution and evaluation of project</li> <li>• Critical appraisal of project for quality, function and finish</li> <li>• Conclusions from practical experience of project work</li> </ul> <p style="text-align: right;"><b>Subtotal</b></p>	<b>30</b>	
<b>C</b>	<b>Manipulative Skills</b> <ul style="list-style-type: none"> <li>• Skills in preparation and finishing of materials</li> <li>• Safe use of tools and machines - Hand /Power/CNC</li> <li>• Skills in assembly of materials</li> </ul> <p style="text-align: right;"><b>Subtotal</b></p>	<b>30</b>	
<b>D</b>	<b>Presentation of Project</b> <ul style="list-style-type: none"> <li>• Task completed to acceptable standard</li> <li>• Appropriate use of materials</li> <li>• Satisfactory knowledge of construction technology</li> </ul> <p style="text-align: right;"><b>Subtotal</b></p>	<b>30</b>	
<b>E</b>	<b>Experiments</b> <ul style="list-style-type: none"> <li>• Evidence of ability to plan and carry out <b>three</b> experiments <i>Experiments should be related to the project work or selected from the suggested experiments outlined in the syllabus for Construction Studies.</i></li> </ul>	Experiment 1 Experiment 2 Experiment 3 <b>Subtotal</b>	
<b>TOTAL:</b>		<b>150</b>	

Signature of Teacher: .....

Date: .....



Scrúdú Ardteistiméireachta 2005

**Staidéar Foirgníochta**

*Breithmheas na Scoile ar Obair Chúrsa Phraiticiúil na nIarrthóirí*

Ainm an Iarrthóra: .....

Scrúduimhir:

An Sórt

Cleachtas Ceardaíochta

Eolaíocht Tógála

Tionscadail:

Scríofa/Tarraingthe le Mionsamhail de réir Scála

Ilchodach

<b>Scéim Mharcála</b>		Uasmhéid Marcanna	Marcanna a Bhronntar
<b>A</b>	<b>Pleanáil an Tionscnaimh</b> <ul style="list-style-type: none"> <li>• Cumas chun plean cuí don nós imeachta a dhearadh</li> <li>• Fianaise faoi thaighde a thaispeáint</li> <li>• Ullmhú líníochtaí oibre/úsáid mionsamhalacha mar áiseanna don ghrafaic</li> </ul> <p style="text-align: right;"><b>Fo-iomlán</b></p>	<b>30</b>	
	<b>B Tuairisc a Scríobh</b> <ul style="list-style-type: none"> <li>• Fóilió dearaidh le sonraí ar phleanáil, ar fheidhmiú agus ar mheastoireacht an tionscnaimh</li> <li>• Measúnú criticiúil ar an tionscnamh maidir le caighdeán, feidhm agus críochnúlacht</li> <li>• Tátail ó thaithí phraiticiúil na hoibre tionscadail</li> </ul> <p style="text-align: right;"><b>Fo-iomlán</b></p>	<b>30</b>	
<b>C</b>	<b>Scileanna Lámhsiúcháin</b> <ul style="list-style-type: none"> <li>• Scileanna in ullmhú agus i mbailchríoch ábhar</li> <li>• Úsáid shábhálta uirlisí agus meaisíní - Lámhe/Cumhachta/CNC</li> <li>• Scileanna i gcóimeáil ábhar</li> </ul> <p style="text-align: right;"><b>Fo-iomlán</b></p>	<b>30</b>	
	<b>D Léiriú an Tionscnaimh</b> <ul style="list-style-type: none"> <li>• Tascanna a críochnú de réir caighdeáin chuí</li> <li>• Úsáid chuí ábhar</li> <li>• Eolas sásúil ar theicneolaíocht tógála</li> </ul> <p style="text-align: right;"><b>Fo-iomlán</b></p>	<b>30</b>	
<b>E</b>	<b>Turgnaimh</b> <ul style="list-style-type: none"> <li>• Léiriú ar chumas ar <b>thrí</b> thurgnamh a phleanáil agus a chur i gcrích</li> </ul> <p><i>Ba cheart go mbeadh baint ag na turgnaimh leis an obair thionscadail nó go roghnófaí iad ó liosta na dturgnamh a leirítear sa siollabas Staidéir Fhoirgníochta.</i></p>	Turgnamh 1	
		Turgnamh 2	
		Turgnamh 3	
		<b>Fo-iomlán</b>	<b>30</b>
<b>MÓR-IOMLÁN:</b>		<b>150</b>	

Siniú an Mhúinteora : .....

Dáta .....